



Higher
Coursework
Assessment Task



Higher Engineering Science Assignment

Assessment task: off-shore wind turbine

This document provides information for teachers and lecturers about the coursework component of this course in terms of the skills, knowledge and understanding that are assessed. It must be read in conjunction with the course specification.

Valid for session 2023-24 only.

This assessment is given to centres in strictest confidence. You must keep it in a secure place until it is used.

This edition: January 2024 (version 1.0)

© Scottish Qualifications Authority 2024

Contents

Introduction	1
Instructions for teachers and lecturers	2
Instructions for candidates	6
Worksheets	22

Introduction

This document contains instructions for teachers and lecturers, and instructions for candidates for the Higher Engineering Science assignment. It must be read in conjunction with the course specification.

This assignment has 50 marks out of a total of 160 marks available for the course assessment.

This is one of two course assessment components. The other component is a question paper.

Instructions for teachers and lecturers

This task is valid for session 2023-24 only. Once complete, you must send the assignment responses to SQA to be marked.

You must conduct the assignment under a high degree of supervision and control.

This means:

- ◆ all candidates must be within your direct sight
- ◆ candidates must not interact with each other
- ◆ candidates must not have access to e-mail, the internet and mobile phones
- ◆ candidates must complete their work independently – no group work is permitted
- ◆ classroom display materials that might provide assistance must be removed or covered
- ◆ there must be no interruption for learning and teaching
- ◆ candidates must be in a classroom environment

Time

Candidates have 8 hours to complete the assignment, starting at an appropriate point in the course after all content has been delivered. Once candidates begin their assignment, they must continue in each subsequent class period until the permitted time allocation has been used up.

You have a responsibility to manage candidates' work, distributing it at the beginning and collecting it at the end of each period, and storing it securely in-between. This activity does not count towards the total time permitted for candidates to complete the assignment.

Resources

This is a closed-book assessment. Candidates must not have access to learning and teaching materials, the internet, notes, exemplar materials, resources on classroom walls or anything similar.

A data booklet containing relevant data and formulae is available on the Higher Engineering Science subject page on SQA's website. This can be used for the assignment.

Each assessment task includes instructions and details of any equipment or materials required for the assignment. Candidates can also use normal classroom equipment, software and hardware (such as drawing instruments, pneumatics, mechanisms and electronics kit, simulation software, and PCs to run the software) to complete the tasks.

There may be instances where restriction of internet and/or network use is not practical or feasible (for example, a local authority-managed network with specific limitations, software that is web-based, or something similar), however, it remains your professional responsibility to make every effort to meet the assessment conditions.

Reasonable assistance

Candidates must progress through each stage of the assignment without your intervention or guidance, having acquired the skills earlier in the course.

Once candidates complete the assignment, you must not return it to them for further work. You must not provide feedback to candidates or offer your opinion on the perceived quality or completeness of the assignment response at any stage.

You can provide reasonable assistance to support candidates with the following aspects of their assignment:

- ◆ printing, collating and labelling their evidence to ensure it is in the format specified by SQA
- ◆ ensuring candidates have all the materials and equipment required to complete the assignment
- ◆ understanding the information outlined in these instructions

Evidence

All candidate evidence (whether created manually or electronically) must be submitted to SQA in paper-based format.

Each task details what evidence is required and how many pages are expected. This is a guide to ensure that candidates do not produce too much or spend too long on a single task.

Candidates must submit single-sided A4 pages. The pages must not have anything fixed to them. Any screenshots, simulation printouts and/or images must be clear and easy to read.

Alteration or adaptation

You must not alter, adapt or modify the assignment in any way. This includes moving the content of the assignment into a different format or workbook. All candidates must undertake the assignment exactly as it is provided by SQA.

Submission

Each piece of work must be labelled with the task number, for example task 2a, and the back of each page must be clearly labelled with the candidate's details.

Photographs must show the candidate's name next to the piece of work.

Only pages containing candidate evidence are to be submitted and evidence must be submitted in task order.

Volume

There is no word or page count.

Specific instructions for teachers and lecturers: 2023-24 assignment

You must follow these specific instructions. You must ensure that candidates are aware of the assessment conditions and know what they should do for each task, and any specific information contained in this section.

This assignment has four mandatory tasks. Candidates can complete the tasks in the order presented or in an order that helps manage classroom equipment.

Each task has a notional time allocated to it – this provides an indication of how long candidates should spend on the task.

All tasks must be completed on A4 single-sided paper or the worksheet provided, with the task number clearly labelled.

Any evidence printed (screenshots or images) must be clear and easy to read.

Task 1 (19 marks)

Notional time: 2 hours 30 minutes

- ◆ completed on up to five single-sided A4 pages
- ◆ task 1a: a worksheet is provided for this task
- ◆ task 1b: a worksheet is provided for this task; candidates must not construct or use simulation software for this task
- ◆ task 1d: a worksheet is provided for this task

Task 2 (15 marks)

Notional time: 2 hours 30 minutes

- ◆ completed on up to four single-sided A4 pages
- ◆ task 2b: a worksheet is provided for this task

Task 3 (3 marks)

Notional time: 30 minutes

- ◆ completed on up to two single-sided A4 pages

Task 4 (13 marks)

Notional time: 2 hours 30 minutes

- ◆ completed on up to three single-sided A4 pages
- ◆ task 4b: a worksheet is provided for this task; candidates must not construct or use simulation software for this task
- ◆ task 4b: pneumatic symbols must not be used, full component names **must** be used
- ◆ task 4c: a worksheet is provided for this task

Note: electronically-generated evidence (for example, simulations and coding) is included in the expected number of pages for each task. This must be printed off and compiled for uplift by SQA.

Instructions for candidates

This assessment applies to the assignment for Higher Engineering Science.

The assignment has 50 marks out of a total of 160 marks for the course assessment.

It assesses the following skills, knowledge and understanding:

- ◆ demonstrating engineering science skills and creativity
- ◆ analysing engineering problems
- ◆ designing and building (simulating and/or constructing) solutions to engineering problems
- ◆ testing and evaluating solutions to engineering problems

This is a closed-book assessment. Your teacher or lecturer will let you know how the assessment will be carried out and any specific conditions for doing it.

In this assessment, you have to:

- ◆ analyse a problem
- ◆ design a solution to the problem
- ◆ simulate or construct your solution
- ◆ test your solution
- ◆ evaluate your work

You have 8 hours to complete the assignment. The time to set and clear away equipment you need, and for any printing that is necessary, does not count towards the 8 hours.

You should complete all of the tasks in the order presented, unless otherwise instructed.

For each task, you are provided with an engineering science context or situation.

The assignment has four tasks, with marks allocated as follows:

Task 1 – 19 marks: analysing a solution (control), designing, building, testing and evaluating a solution (electronics) for the turbine head position control system (analysis = 7 marks, designing = 2 marks, building = 2 marks, testing = 4 marks, evaluating = 4 marks)

Task 2 – 15 marks: building, testing and evaluating a solution (electronics and programmable control) for a blade inspection robot (building = 4 marks, testing = 7 marks, evaluating = 4 marks)

Task 3 – 3 marks: building a solution (structures) for a turbine head lifting platform (building = 3 marks)

Task 4 – 13 marks: designing a solution (electronics), designing and testing a solution (pneumatics) for a blade impact testing system
(designing = 10 marks, testing = 3 marks)

For each task, you are provided with an engineering science context or situation.

Submitting your work

Your teacher or lecturer will let you know the approximate amount of time to spend on each task, along with any specific information you need and an indication of the number of single-sided A4 pages of evidence that you should produce.

You must label each piece of your work with the task number (for example, task 2a), and on the back of each page include your:

- ◆ name
- ◆ date of birth
- ◆ Scottish Candidate Number (SCN)
- ◆ centre name
- ◆ centre number

Candidate data sheets – off-shore wind turbine

You can use these data sheets and SQA’s Higher data booklet when completing this assignment. No other resource material is permitted.

Electronic components

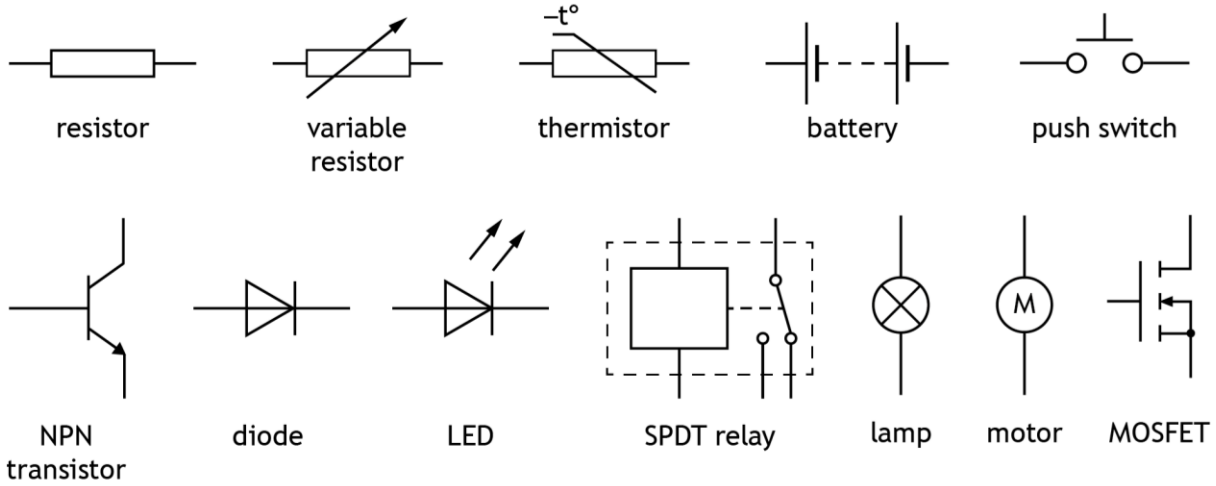

IC pinout diagrams

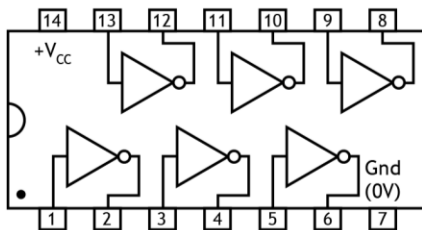

7404

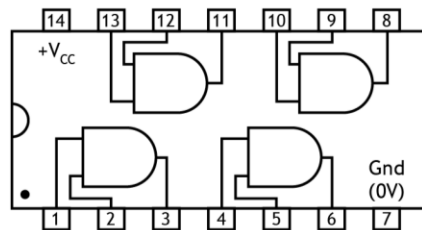

7408

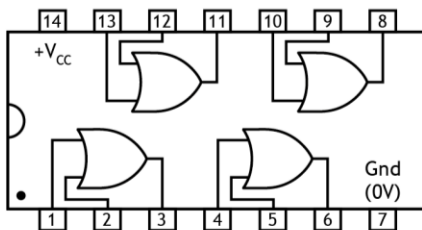

7432

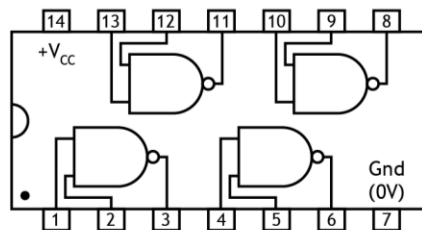

7400

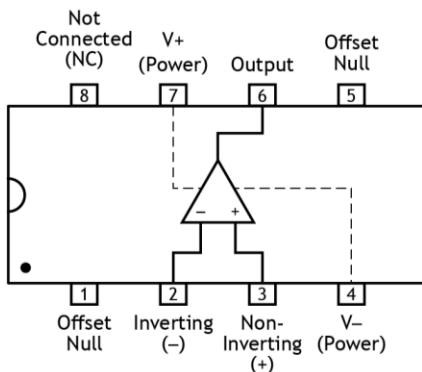

741

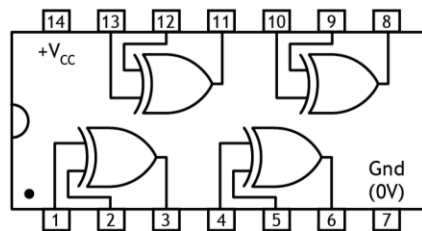

7486

Logic gates

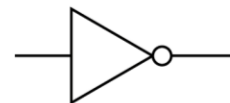

NOT gate

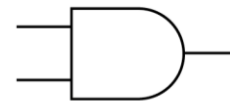

AND gate

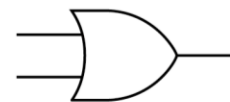

OR gate

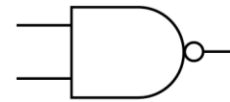

NAND gate



NOR gate



XOR gate

Thermistor graph

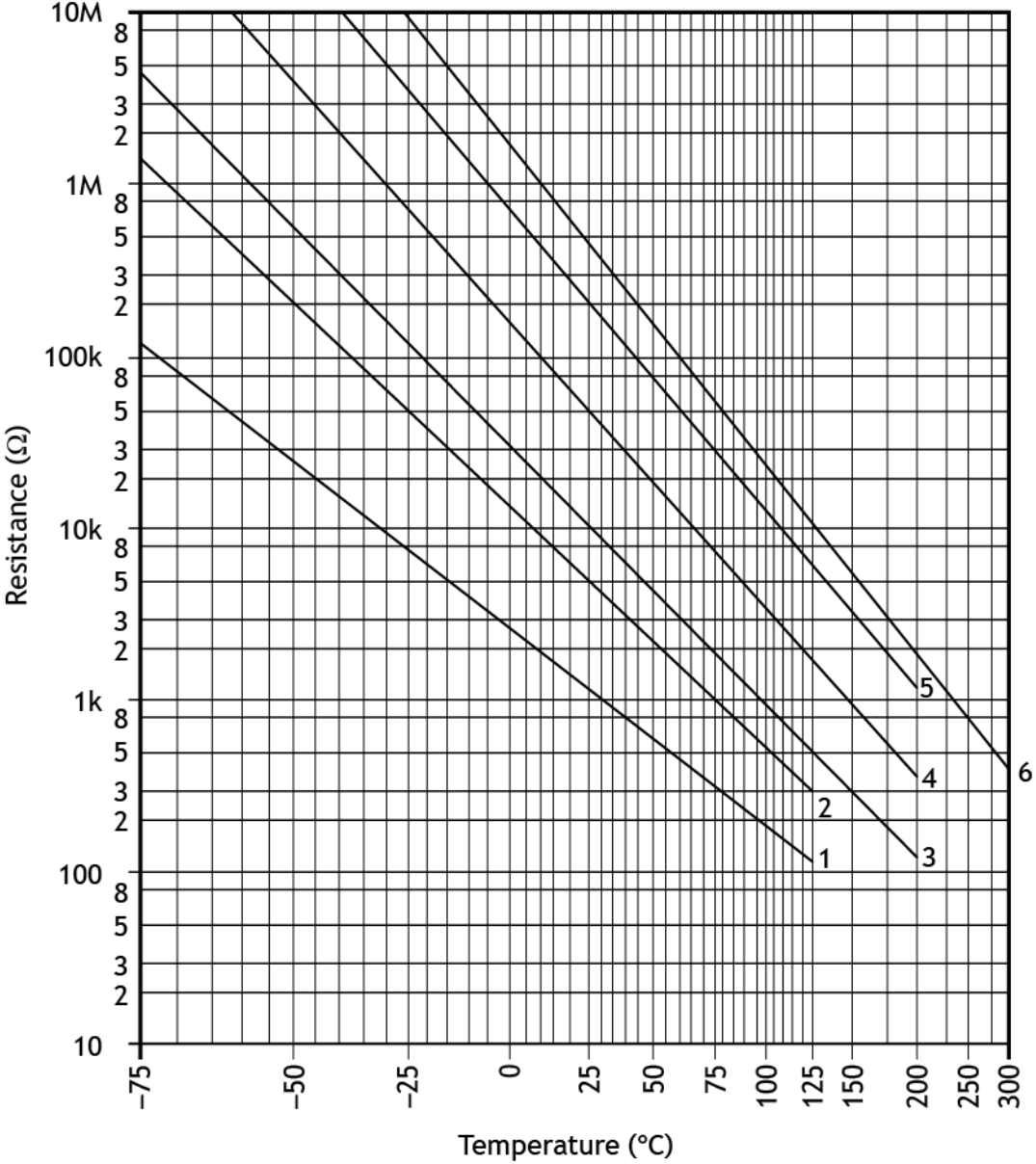

Light Dependent Resistor (LDR) graph for an ORP12 LDR

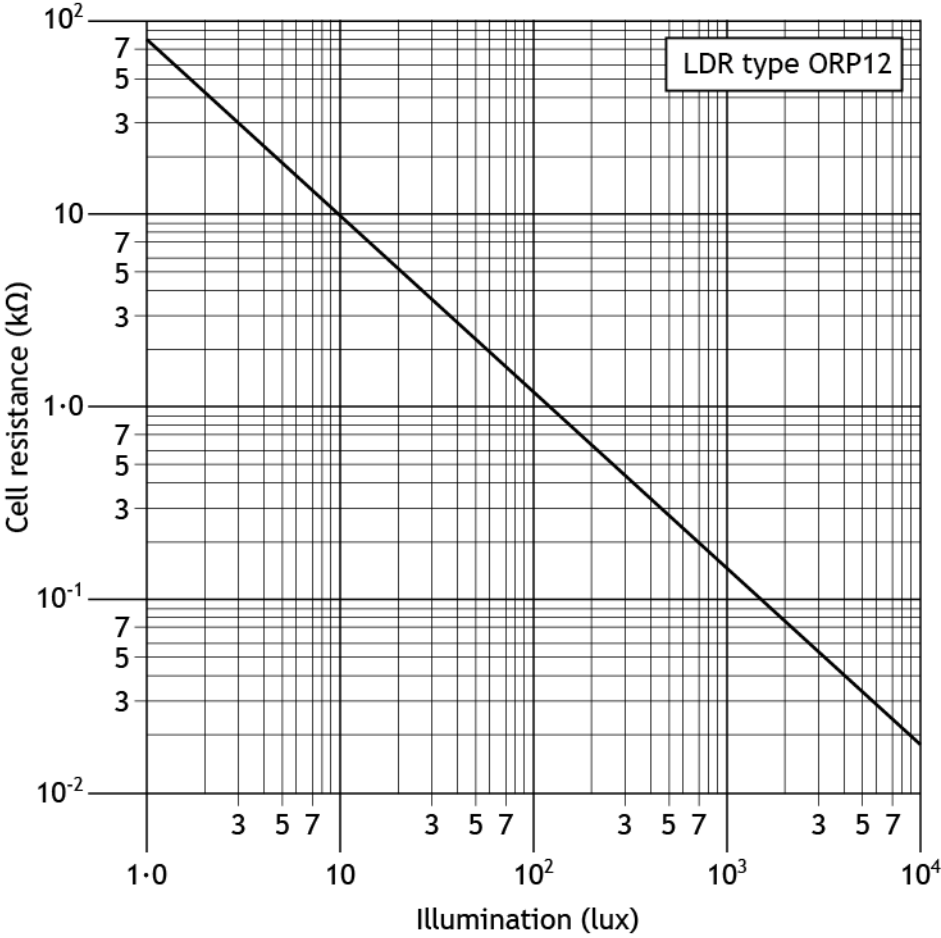

Pneumatic components

Actuators



spring return



pilot air



roller



solenoid



lever



diaphragm



roller trip



plunger



push button

Valves

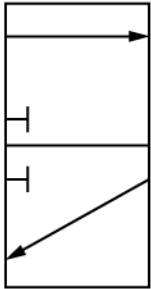

3/2 valve

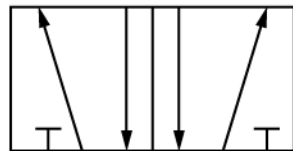

5/2 valve

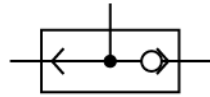

shuttle valve



main air



exhaust

Components and cylinders



unidirectional restrictor

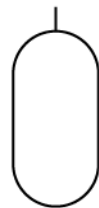

reservoir

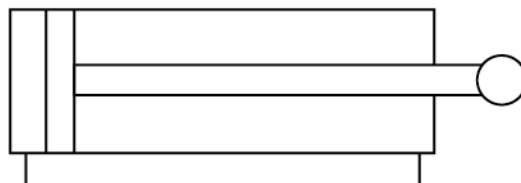

double acting cylinder

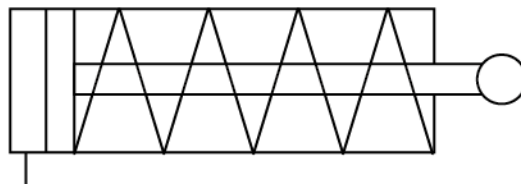

single acting cylinder

Off-shore wind turbine

A team of engineers is involved in the design and maintenance of an off-shore wind turbine.



The engineers work on a variety of tasks to ensure efficiency and safe working as follows:

Task 1 – turbine head position control system

Task 2 – blade inspection robot

Task 3 – turbine head lifting platform

Task 4 – blade impact testing system

Task 1 – turbine head position control system

An electronic control system keeps the wind turbine head facing into the wind.

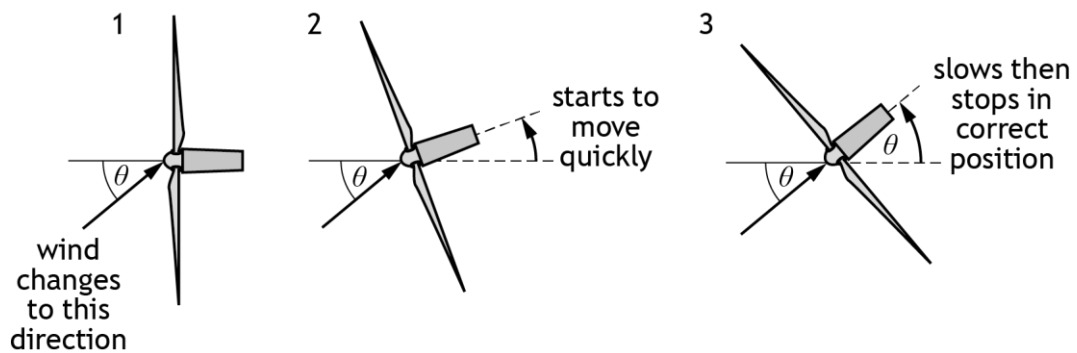
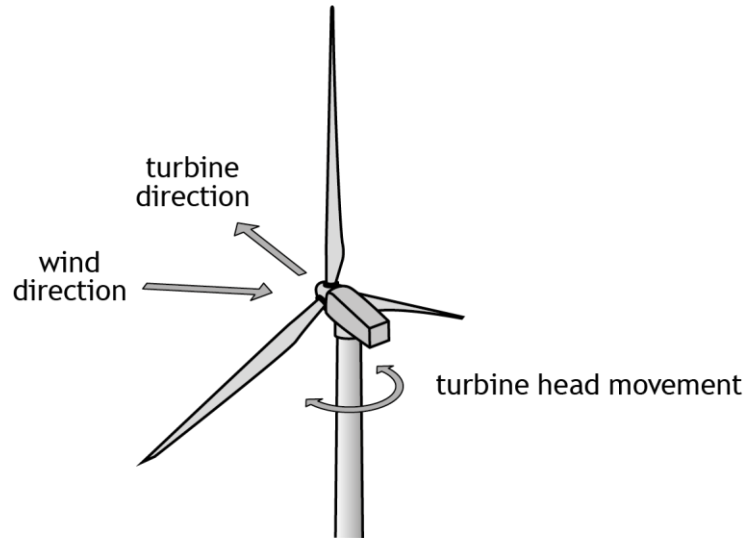

The control diagram for the electronic control system is shown below.

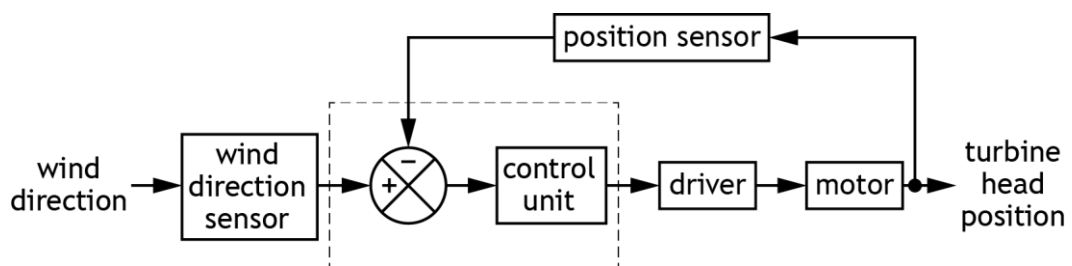

1a Analyse the above information and write a specification for the control diagram.

Present your evidence on **worksheet 1a** on A4 single-sided pages, with the task number clearly labelled.

(6 marks)

Task 1 – turbine head position control system (continued)

An operational amplifier circuit is needed to perform the function shown in the control diagram. A simulation will be used to test that the circuit operates as intended.

The electronic circuit must meet the following specification:

- i Variable voltage supplies (maximum 10 mV) are used as inputs V_1 and V_2 .
- ii V_1 is connected to the inverting input of the operational amplifier.
- iii The operational amplifier is supplied with +9 V and -9 V.
- iv The operational amplifier has a gain of 30.
- v The voltage output of the operational amplifier must be able to change polarity and magnitude as input conditions change.

Note: V_1 represents the signal from the wind direction sensor and V_2 represents the signal from the position sensor.

- 1b Using **worksheet 1b**, design an operational amplifier circuit to meet the specification.

Note: you must not construct or use simulation software to complete this part of the task.

Present your evidence on A4 single-sided pages, with the task number clearly labelled.

(3 marks)

- 1c Simulate or construct the operational amplifier circuit designed in **task 1b**.

Present your evidence on A4 single-sided pages, with the task number clearly labelled. Screenshots or images must be clear and easy to read.

(2 marks)

- 1d Complete the testing table on **worksheet 1d**, by carrying out the planned tests and describing each initial test result.

Describe your amendments to the operational amplifier circuit, so that it meets the specification and make the amendments.

Carry out each test again, describing the result of your retest, before moving onto the next test.

Present your evidence on A4 single-sided pages, with the task number clearly labelled.

(4 marks)

Task 1 – turbine head position control system (continued)

1e Evaluate the performance of your amended solution from **task 1d** against points iv and v in the specification for **task 1b**, by describing:

- ◆ how your amended solution meets both specification points iv and v (you must do this by referring to testing and any amendments you may have made)
- ◆ the overall effectiveness of your amended solution in controlling the position of the turbine head
- ◆ any suggested improvements that could be made

Present your evidence on A4 single-sided pages, with the task number clearly labelled.

(4 marks)

Task 2 – blade inspection robot

A microcontroller is used to operate a blade inspection robot. During hostile weather conditions, the robot checks the turbine blades for surface defects and repairs them.



An electronic engineer has designed the flowchart and circuit shown below as a possible simplified solution, using a motor for movement and a solenoid for repairs.

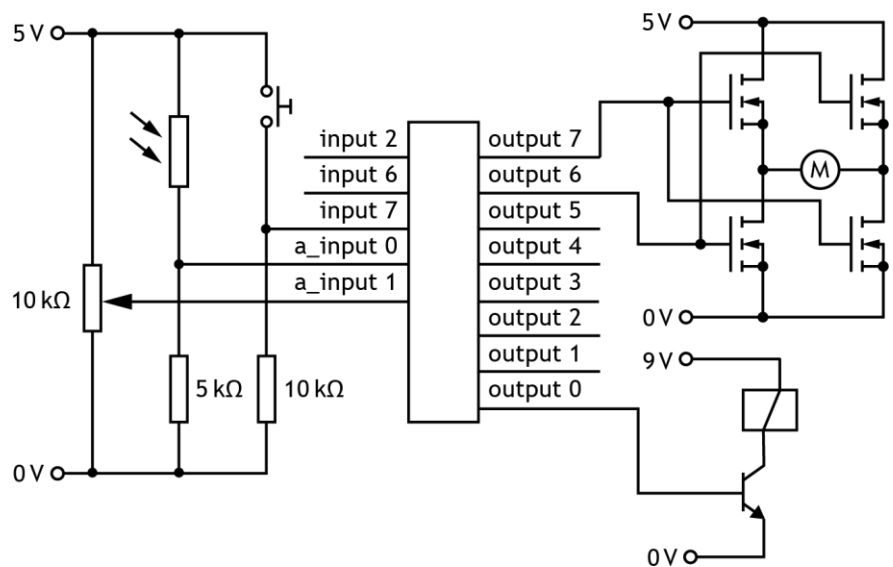
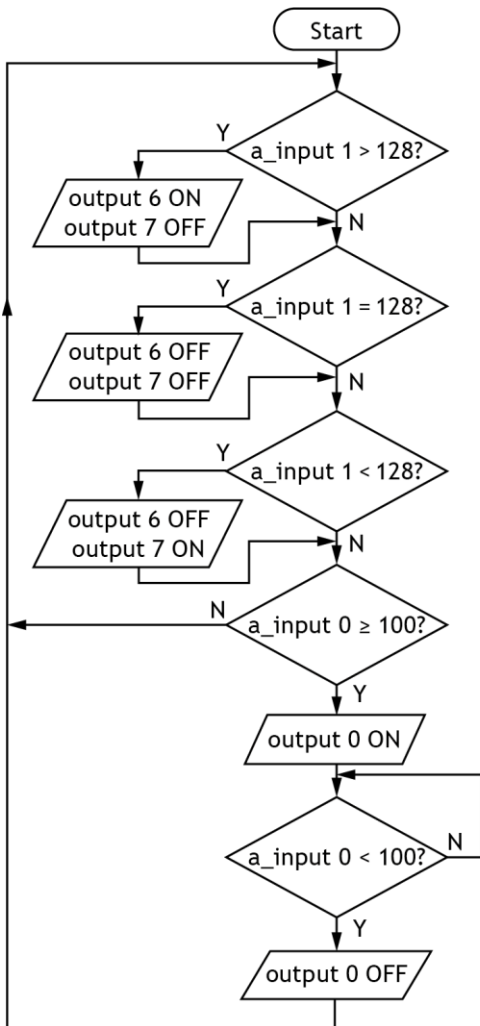

Microcontroller pin connections			
a_input 0	light sensor	output 0	solenoid
a_input 1	control input	output 6	motor anticlockwise
input 7	'master' switch	output 7	motor clockwise

Task 2 – blade inspection robot (continued)

- 2a Simulate or construct the flowchart and electronic circuit integrated together as shown.

Present your evidence on A4 single-sided pages, with the task number clearly labelled. Screenshots or images must be clear and easy to read.

(4 marks)

The microcontroller must meet the following specification:

- i The robot will not operate unless the ‘master’ switch has been pressed on the controller.
- ii When the control input is set to a value of 128, the motor will be off. If the input is above 128, the motor will rotate clockwise (via output 7), and if the input is below 128, the motor will rotate anticlockwise (via output 6).
- iii If a defect on the surface of the blade is detected by the light level sensed being above a certain value, the solenoid output will apply the repair resin. When the light level sensed decreases to the certain value, the solenoid output will switch off.

Errors were found in both the electronic circuit and the flowchart during testing.

- 2b Complete the table on **worksheet 2b**, by carrying out the planned tests and describing the actual results you observed.

Describe the amendments you made to enable the system to meet the specification, before moving on to the next test.

Present your evidence on A4 single-sided pages, with the task number clearly labelled.

(7 marks)

- 2c Using your amended solution from **task 2b**, evaluate the performance against the specification for the blade inspection robot.

Describe how your amended solution meets each of the three specification points, referring to testing, any amendments that you have made and any further testing you carried out.

Present your evidence on A4 single-sided pages, with the task number clearly labelled.

(4 marks)

Task 3 – turbine head lifting platform

During maintenance, sections of the turbine head will be supported on a lifting platform.

To design the lifting platform, a simulation of part of the structure is used to determine the reactions and forces in particular joints.

A diagram of the structure is shown below. The distance from A to B is 6 m.

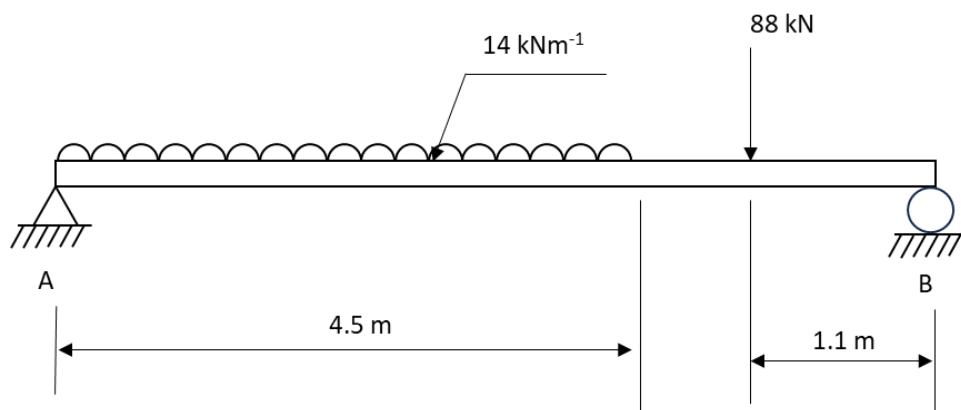

3 Simulate this structure to determine the vertical reactions at supports A and B.

Your evidence of simulation must:

- Indicate the vertical reaction at support A
- Indicate the vertical reaction at support B
- Provide proof of the simulation

Present your evidence on A4 single-sided pages, with the task number clearly labelled. Screenshots or images must be clear and easy to read.

(3 marks)

Task 4 – blade impact testing system

The blades need to be impact tested regularly.

The testing system has a digital logic circuit which controls the operation of a pneumatic system. The pneumatic system is designed to simulate forces acting against the turbine blade when in use.

The digital logic circuit must meet the following specification:

- i The digital logic circuit can only give a high output (Z) if both a ‘master switch’ (B) and ‘area check clear’ switch (A) have been pressed.
 - ii The digital logic circuit can only work if either ‘operator switch’ (C) or ‘operator switch’ (D) have been pressed, but not both.
- 4a Design a digital logic circuit to perform this function.

Present your evidence on A4 single-sided pages, with the task number clearly labelled.

(2 marks)

Task 4 – blade impact testing system (continued)

The digital logic circuit is replaced with a microcontroller circuit to test the turbine blade. This will allow programmable control to simulate different forces acting on the turbine blade.

The circuit must meet the following specification:

- i Cylinder C_A outstrokes slowly and smoothly to clamp the blade into its testing position when valves V_1 and V_2 are both actuated.
 - ii Valve V_1 is actuated when it receives a high signal from pin 6 on the microcontroller, and valve V_2 is actuated and de-actuated manually by a lever.
 - iii When valve V_4 receives a high signal from pin 4, cylinder C_A instrokes to unclamp the blade from its test position.
 - iv Valve V_3 receives constantly alternating high and low signals from pin 7, causing cylinder C_B to constantly outstroke and instroke, impacting on the turbine blade.
- 4b Design a pneumatic circuit on **worksheet 4b**, using a block diagram (not pneumatic symbols) to represent components.

Give the full name of each pneumatic component in the diagram.

Show the correct line types for piping and indicate the outstroke direction of any cylinders.

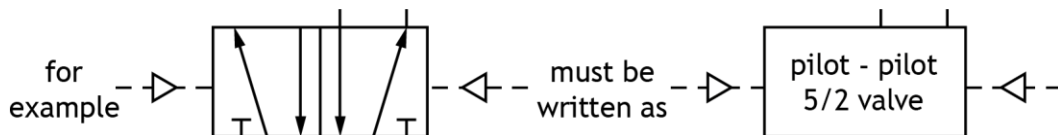

Note: you must not construct or use simulation software to complete this part of the task. Not all component boxes have been drawn pre-drawn on the worksheet.

Present your evidence on A4 single-sided pages, with the task number clearly labelled.

(8 marks)

Task 4 – blade impact testing system (continued)

After the blade impact testing system is constructed, it must be tested to ensure it operates correctly.

Programmable control is used to operate the pneumatic circuit. A programmer has written the code for the microcontroller to meet the specification on page 20.

The code designed uses a pulse width modulation (PWM) duty cycle of 25% (1:3) to operate cylinder C_B.

4c Design a test plan for the pneumatic circuit, using **worksheet 4c**.

You must include a planned test and expected result for:

- ◆ outstroking cylinder C_A
- ◆ cylinder C_B to instroke and outstroke using PWM
- ◆ instroking cylinder C_A

Make reference to the signal from the microcontroller output pins 4, 6 and 7 in your testing.

Present your evidence on A4 single-sided pages, with the task number clearly labelled.

(3 marks)

[END OF ASSIGNMENT]



Higher
Coursework
Assessment Task



Higher Engineering Science Assignment Assessment task: off-shore wind turbine

Worksheets

Valid for session 2023-24 only.

Worksheet 1a

Specification 1	
Specification 2	
Specification 3	
Specification 4	
Specification 5	
Specification 6	

(6 marks)

Name:	
Date of birth:	
Scottish Candidate Number (SCN):	
Centre name:	
Centre number:	

Worksheet 1b

variable
voltage supply V_1 

variable
voltage supply V_2 

0V 

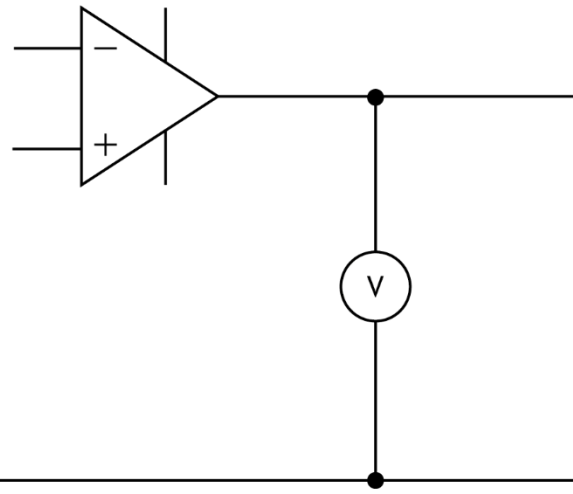

(3 marks)

Name:	
Date of birth:	
Scottish Candidate Number (SCN):	
Centre name:	
Centre number:	

Worksheet 1d

Planned test	Expected result	Actual result	Amendments made
Set both V_1 and V_2 to 5 mV.	The output voltage is 0 V.		
Set V_1 to 10 mV and set V_2 to 0 mV.	The output voltage should be + 300 mV.		
Set V_1 to 4 mV and set V_2 to 6 mV.	The output voltage should be - 60 mV.		

(4 marks)

Name:	
Date of birth:	
Scottish Candidate Number (SCN):	
Centre name:	
Centre number:	

Worksheet 2b

Planned test	Expected result	Actual result	Amendments made
Activate the flowchart. Press the 'master' switch.	The robot program will run.		
Alter analogue input 1 maximum value, then activate the flowchart. Press the 'master' switch.	Output 7 switches on and the motor turns.		
Alter analogue input 0 LDR to the maximum light level, then activate the flowchart. Press the 'master' switch. Repeat this test.	The solenoid will energise and actuate each time.		

(7 marks)

Name:	
Date of birth:	
Scottish Candidate Number (SCN):	
Centre name:	
Centre number:	

Worksheet 4b

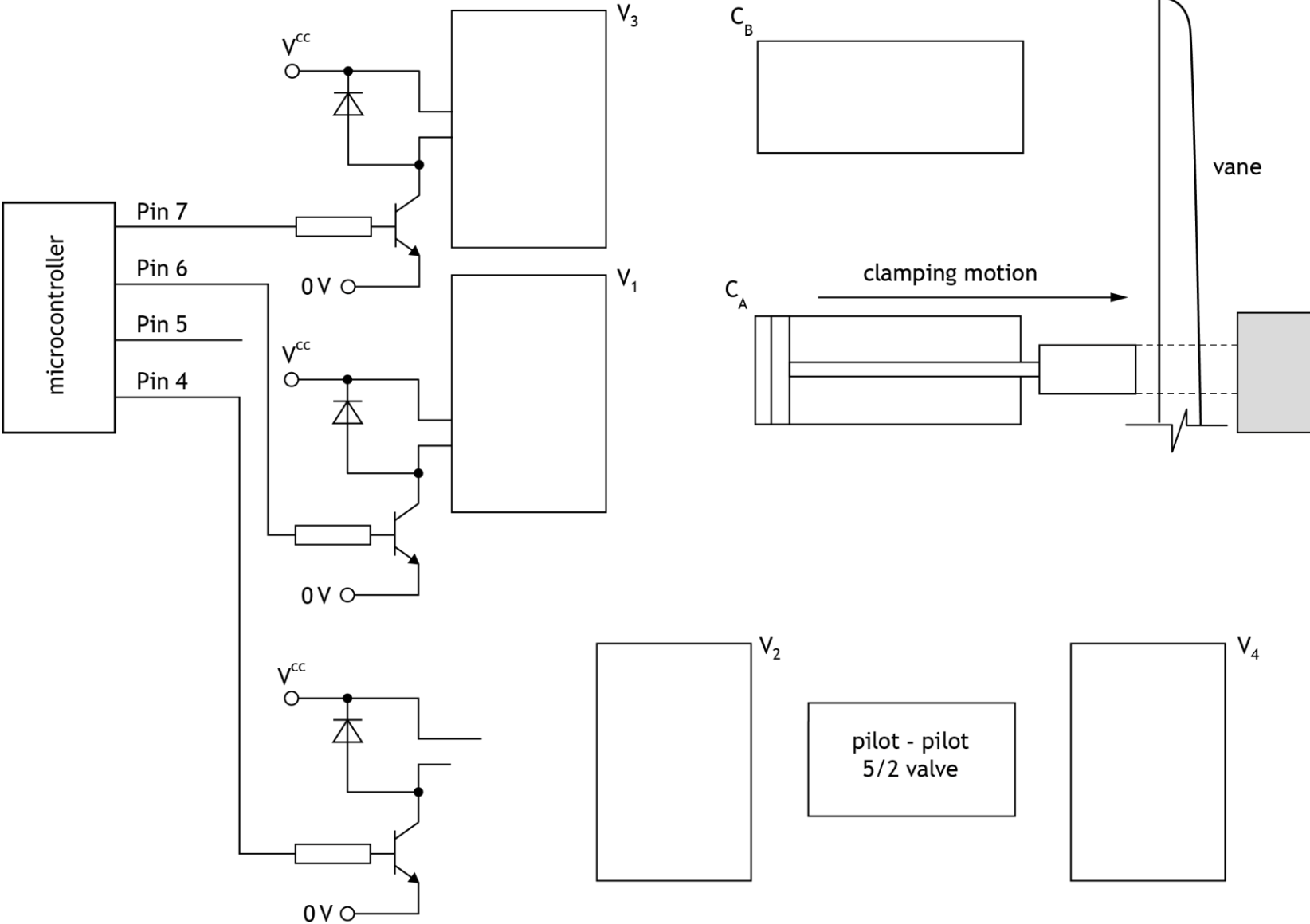

(8 marks)

Name:	
Date of birth:	
Scottish Candidate Number (SCN):	
Centre name:	
Centre number:	

Worksheet 4c

Planned test	Expected result

(3 marks)

Name:	
Date of birth:	
Scottish Candidate Number (SCN):	
Centre name:	
Centre number:	

Copyright acknowledgements

Page 12 – F Schmidt/Shutterstock.com

Page 16 – <https://ore.catapult.org.uk/stories/bladebug/>

SQA has made every effort to trace the owners of copyright of this item and seek permissions. We are happy to discuss permission requirements and incorporate any missing acknowledgement. Please contact question.papers@sqa.org.uk.

Administrative information

Published: January 2024 (version 1.0)

History of changes

Version	Description of change	Date

Security and confidentiality

This document can be used by SQA approved centres for the assessment of National Courses and not for any other purpose.

This document may only be downloaded from SQA's designated secure website by authorised personnel.

© Scottish Qualifications Authority 2024