

FOR OFFICIAL USE



--	--	--	--	--	--

National
Qualifications
2018

Mark

--

X735/76/01

Graphic Communication

THURSDAY, 10 MAY

1:00 PM – 3:00 PM



Fill in these boxes and read what is printed below.

Full name of centre

--

Town

--

Forename(s)

--

Surname

--

Number of seat

--

Date of birth

Day

--	--

Month

--	--

Year

--	--

Scottish candidate number

--	--	--	--	--	--	--	--	--	--

Total marks — 70

Attempt ALL questions.

All dimensions are in mm.

All technical sketches and drawings use third angle projection.

You may use rulers, compasses or trammels for measuring.

In all questions you may use sketches and annotations to support your answer if you wish.

Write your answers clearly in the spaces provided in this booklet. Additional space for answers is provided at the end of this booklet. If you use this space you must clearly identify the question number you are attempting.

Use **blue** or **black** ink.

Before leaving the examination room you must give this booklet to the Invigilator; if you do not, you may lose all the marks for this paper.



Downloaded free from <https://sqa.my/>

Total marks — 70
Attempt ALL questions

1. An exploded view and an assembled view of a tablet stand are shown below.



The tablet stand was designed using **bottom up modelling**.

(a) Explain the term **bottom up modelling** in relation to the assembled tablet stand.

2



1. (continued)

(b) The base for the tablet stand was created using tangency and ellipse construction, as shown below.

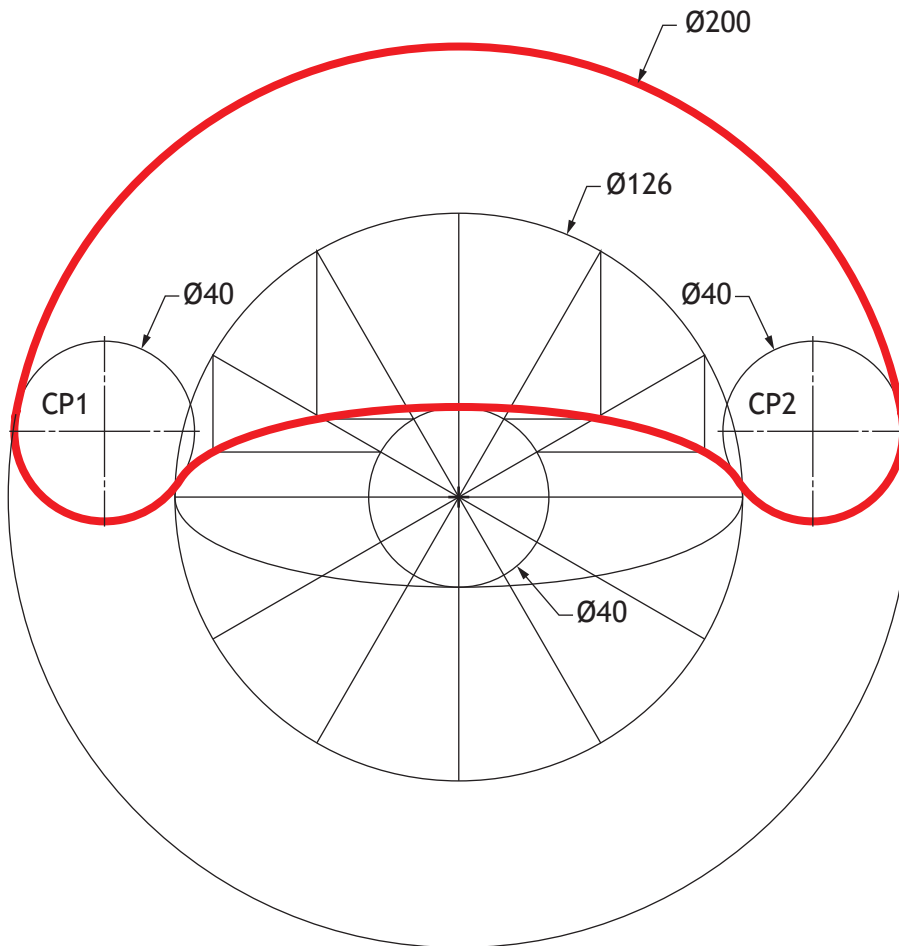

State, with reference to the 2D drawing shown above:

(i) the length of the major axis of the ellipse; 1

(ii) the length of the minor axis of the ellipse. 1

[Turn over



1. (continued)

(c) The base for the tablet stand is to be modelled using 3D CAD. A 2D production drawing of the tablet stand is shown below.

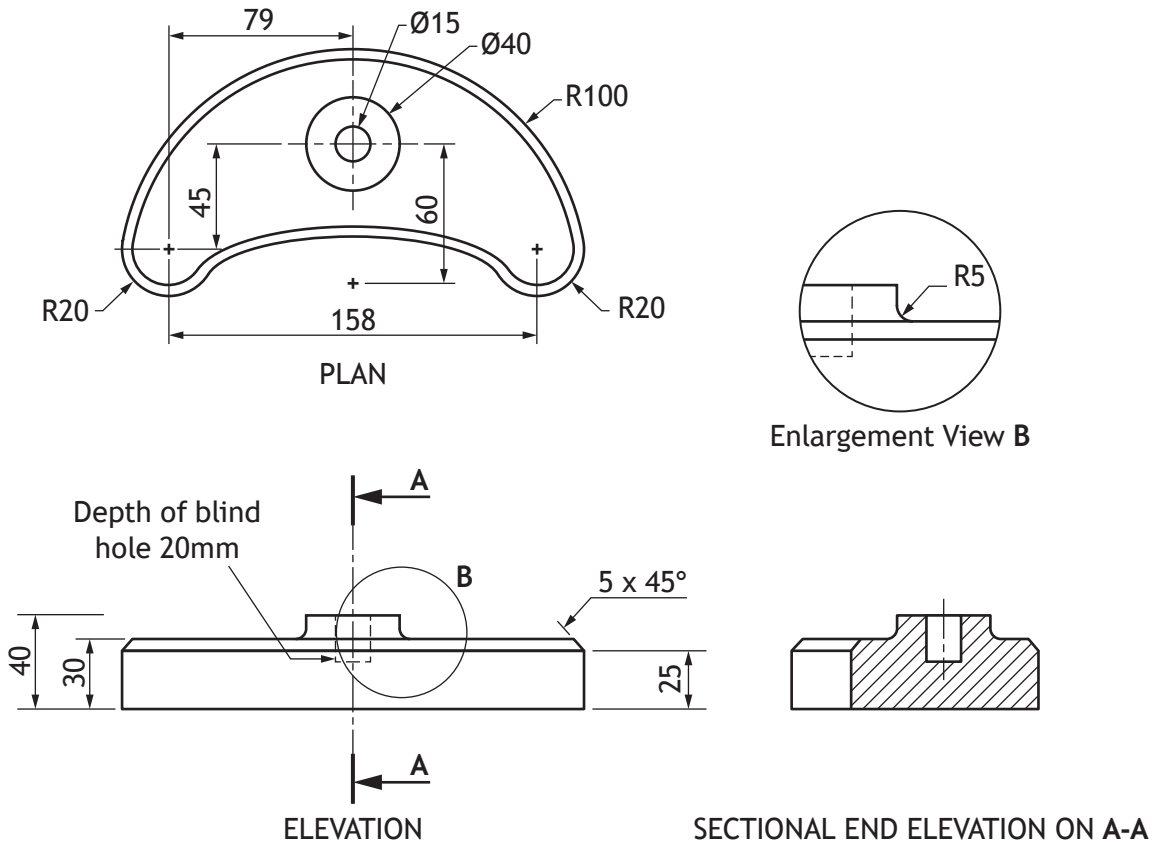

* X 7 3 5 7 6 0 1 0 4 *

1. (c) (continued)

Describe the 3D CAD modelling techniques used to create this component. You must make reference to the dimensions shown in the 2D production drawing opposite.

You may use sketches to support your answer.

4

[Turn over



* X 7 3 5 7 6 0 1 0 5 *

1. (continued)

- (d) A pictorial view of the support arm for the tablet stand is shown below. Also shown is a 2D production drawing.

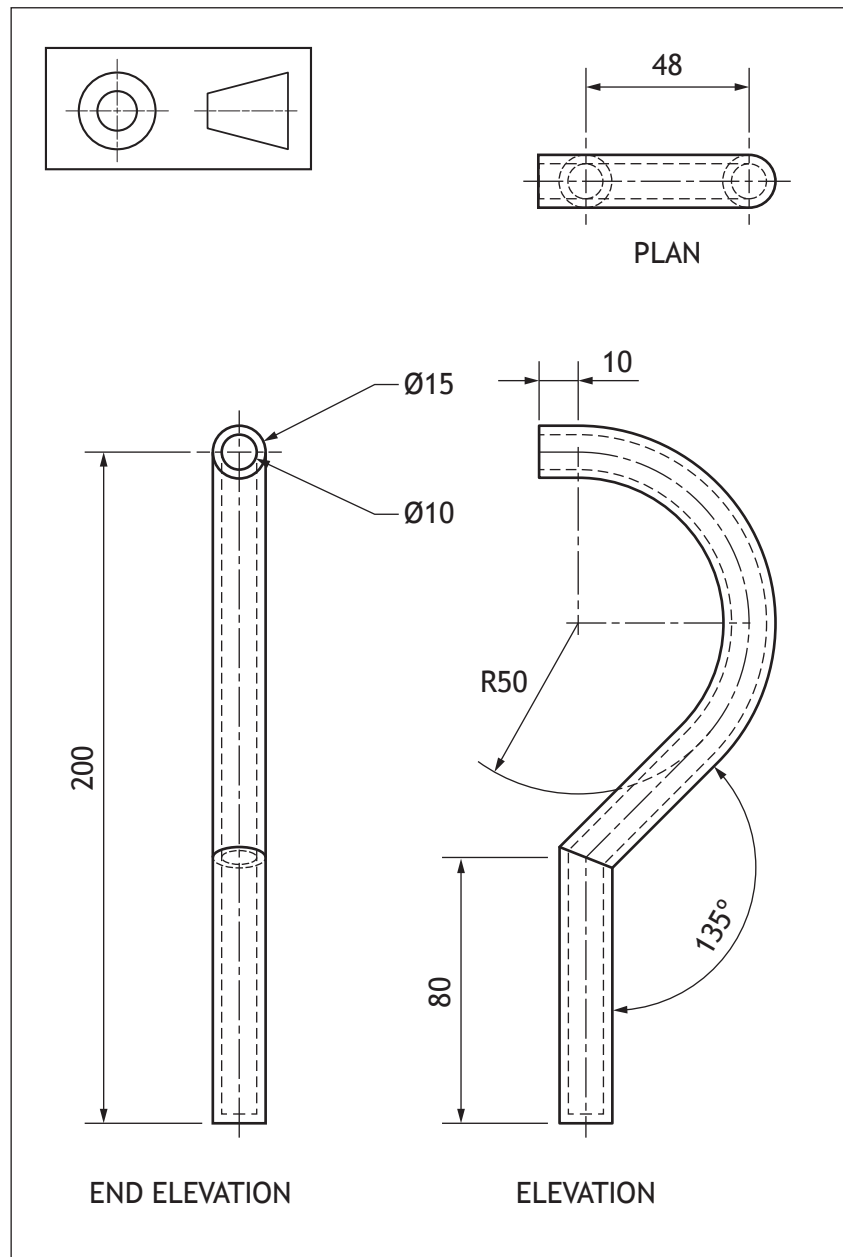
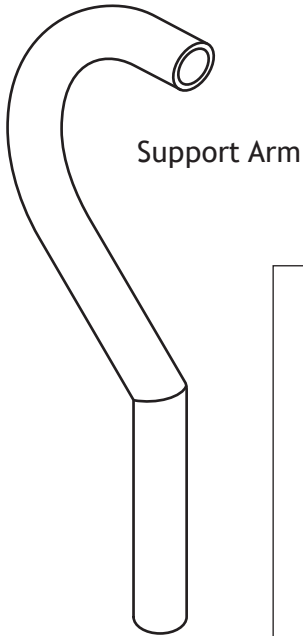

1. (d) (continued)

Describe the 3D CAD modelling techniques used to create the support arm. You must make reference to the dimensions shown in the 2D production drawing opposite.

You may use sketches to support your answer.

3

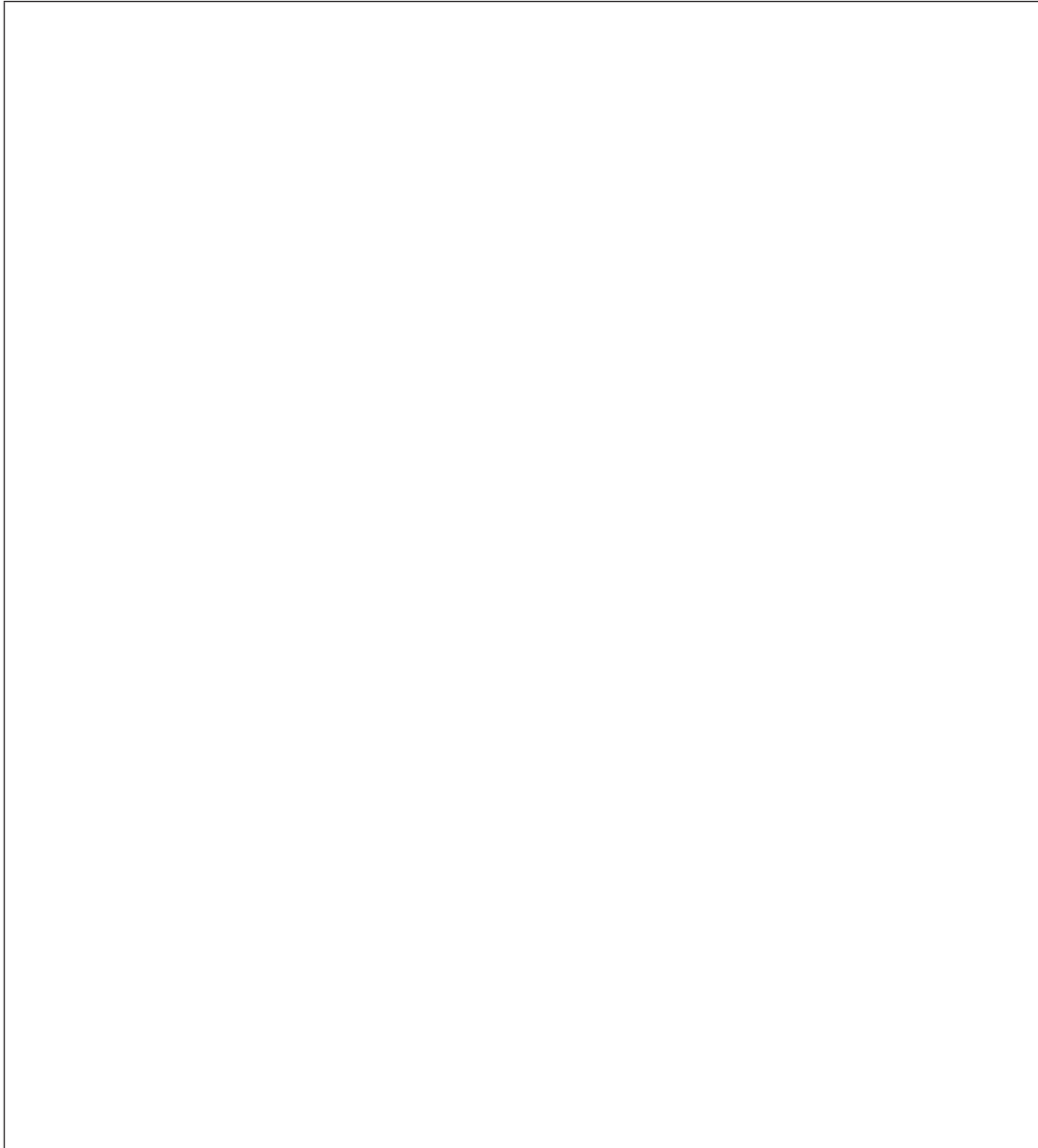

[Turn over



* X 7 3 5 7 6 0 1 0 7 *

1. (continued)

MARKS DO NOT WRITE IN THIS MARGIN

- (e) A pictorial view of the ball joint for the tablet stand is shown below. Also shown is a 2D production drawing.

Describe the **single** 3D CAD modelling technique used to create the ball joint component. You must refer to the dimensions given in the drawing shown below.

3

You may use sketches to illustrate your answer.

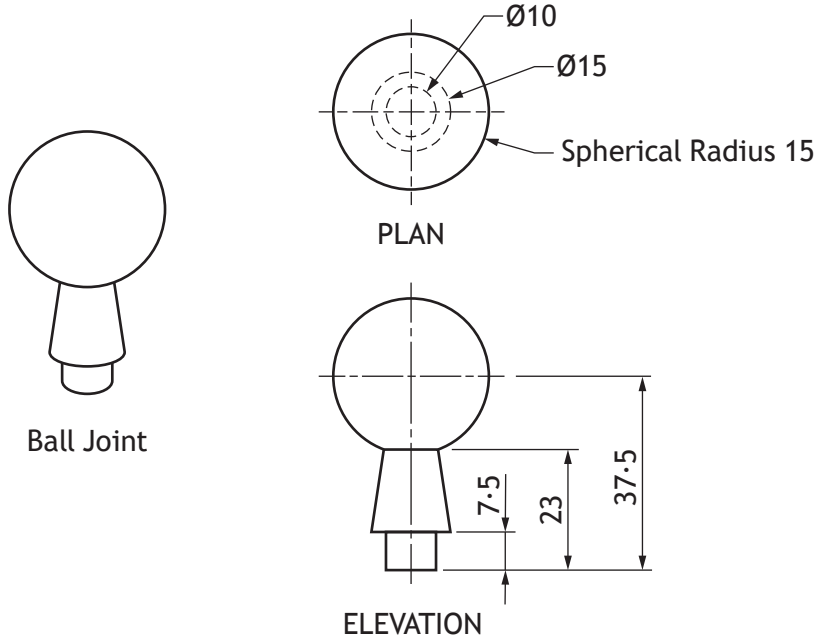

In order for the ball joint to work effectively a functional tolerance needs to be applied to it.

- (f) Using British Standard conventions, apply a diameter tolerance of 10 mm $+0.15$ and -0.25 to the graphic below.

2

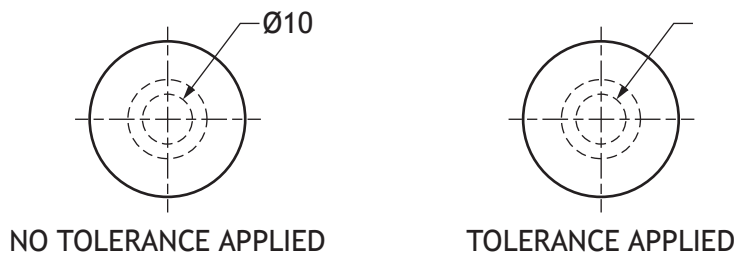

1. (continued)

MARKS

DO NOT
WRITE IN
THIS
MARGIN

- (g) Two pictorial views of the ball socket for the tablet stand are shown below. Grips were added to help the user adjust the angle of the tablet. Also shown is a 2D production drawing.

Describe the 3D CAD techniques used to create the **grips** on the ball socket component. You must refer to the dimensions given in the drawings shown below.

3

You may use sketches to support your answer.

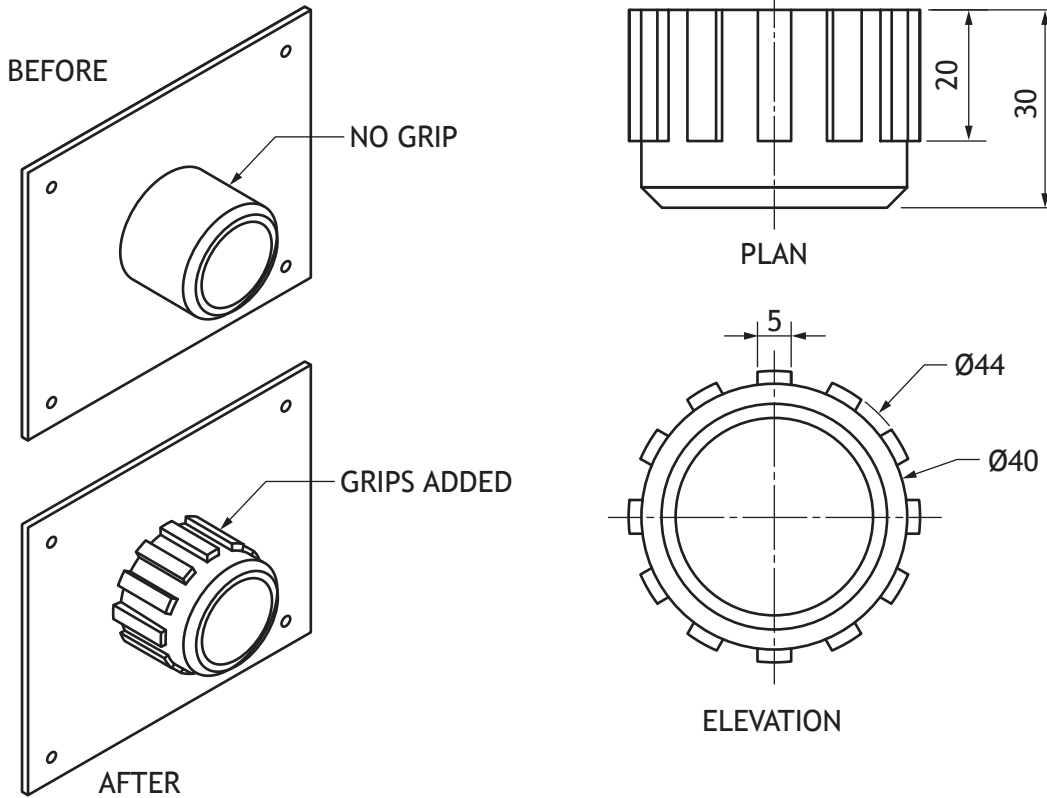

* X 7 3 5 7 6 0 1 0 9 *

1. (continued)

(h) When reviewing the final model of the ball socket, the CAD technician decided to reduce the number of grips on the ball socket from 12 to 10.

(i) Describe how the modelling tree is used to edit the number of grips.

1

(ii) Explain why editing the modelling tree is an efficient way of changing the number of grips.

1

2. A product is manufactured abroad. The 3D modelling files are sent electronically to the manufacturer. The 3D modelling files will be sent in the IGES file format.

(a) (i) Name another suitable 3D modelling file format that could have been used.

1

(ii) Explain why using these file formats is advantageous to the manufacturer.

1



2. (continued)

The manufacturer has also requested that the production drawings are sent electronically.

- (b) Explain why it is advantageous to the manufacturer to receive a vector graphic rather than a raster graphic. 1

- (c) The production drawings are created by CAD technicians and include several components from a CAD library. 2

Describe two benefits a CAD library offers a CAD technician.

- (d) (i) State the name of the British Standard symbol shown below. 1

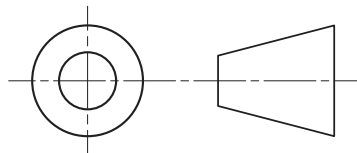

- (ii) Explain why this symbol is useful to the manufacturer. 1

[Turn over



3. Two different types of graphics are shown below.

Promotional



Production

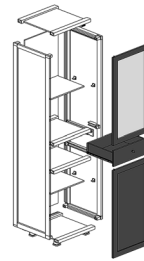

(a) Explain the purpose of each of the graphics shown.

(i) Promotional

1

(ii) Production

1

(b)



A customer used a popular kitchen design website to quickly generate a range of initial designs for the layout of their kitchen, as shown above.

Describe two advantages of using digital methods compared to manual sketching methods at this stage in the process.

2



4. Graphics for a spotlight are shown below.

MARKS
DO NOT
WRITE IN
THIS
MARGIN

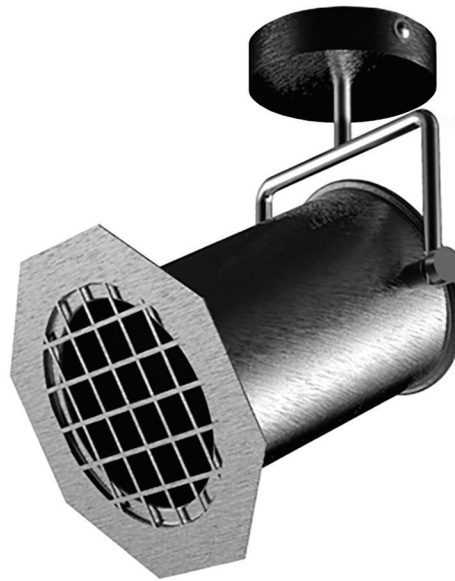

The spotlight casing (part 6) has two raised bosses to allow the mounting bracket (part 4) to be screwed on.

You must refer to the supplementary sheet for use with question 4, provided, to answer all parts of this question.

(a) Calculate the size for dimension X for the boss shown below.

Maximum size of X _____ mm

1

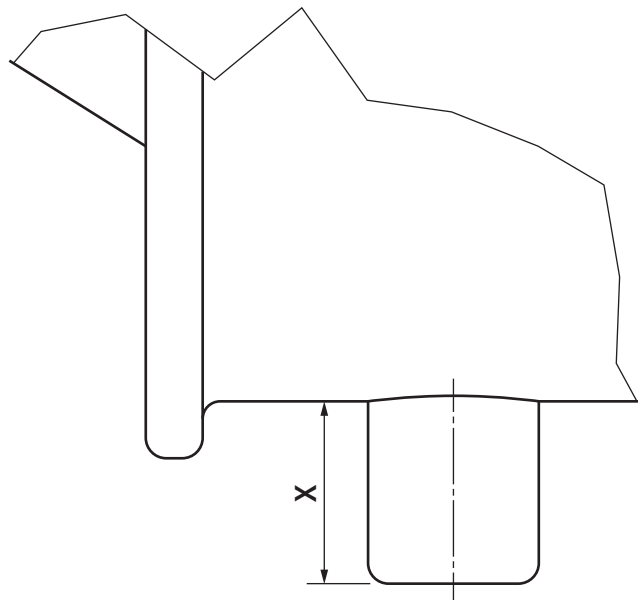

ENLARGED PARTIAL VIEW A

[Turn over



* X 7 3 5 7 6 0 1 1 3 *

4. (continued)

MARKS
DO NOT
WRITE IN
THIS
MARGIN

(b) An elevation and end elevation of the spotlight are given below.

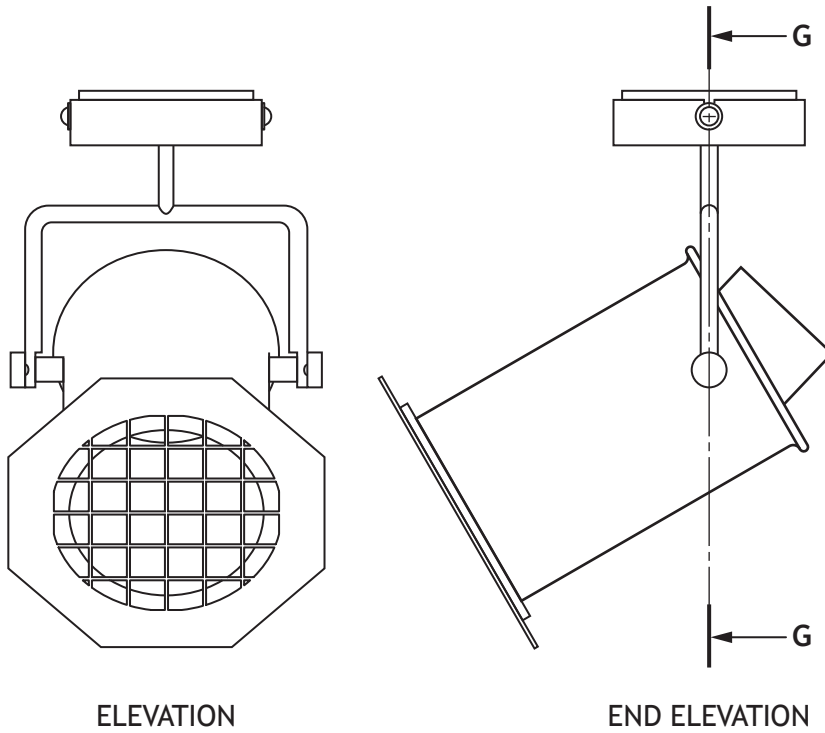

(i) A partial view of section G-G is shown below.

Apply hatching to this drawing in accordance with British Standard conventions.

4

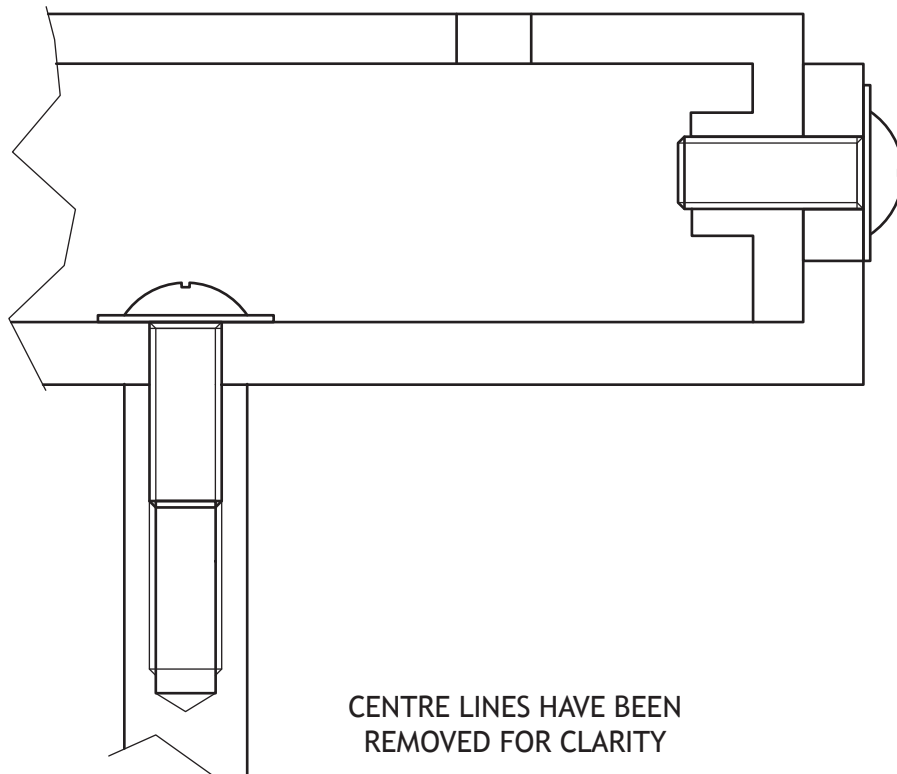

4. (b) (continued)

- (ii) The thumb screws are available with two types of grips on the heads, **straight knurling** or **diamond knurling**.

Apply the British Standard convention for each type of knurling below.

2

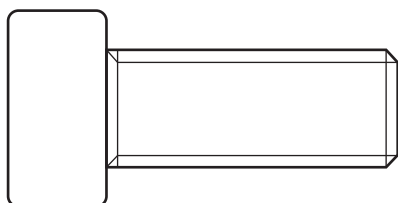

STRAIGHT KNURLING

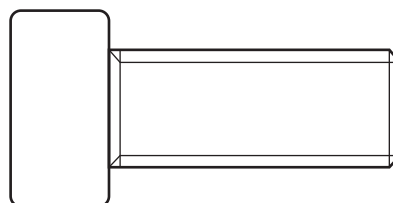

DIAMOND KNURLING

- (c) The thumb screws are replaced with hand screws, which are easier for the user to grip. A rendered illustration and front elevation for the hand screw are shown below.

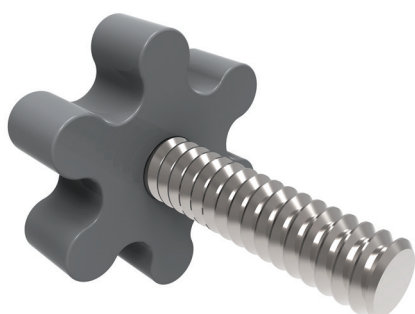

RENDERED ILLUSTRATION OF HAND SCREW

6 x R2.75
Equi SP
on 20 PCD

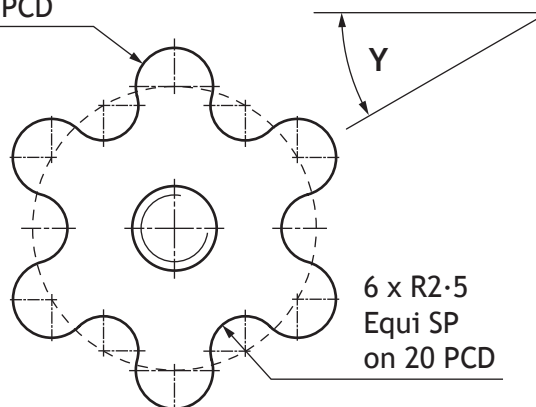

6 x R2.5
Equi SP
on 20 PCD

ELEVATION

- (i) State what PCD stands for in the drawing above.

1

- (ii) Calculate the angle Y shown in the drawing above.

1

[Turn over



* X 7 3 5 7 6 0 1 1 5 *

5. Use the draft infographic on the **supplementary sheet for use with question 5**, provided, to answer all parts of this question.

A graphic artist has produced a draft infographic, which gives readers advice on how to save money on their energy bills.

- (a) Describe how the graphic artist has used **shape** to create **rhythm**. 2

- (b) Explain why the graphic artist's use of **grid structure** is of benefit to the reader. 2

- (c) Describe how the graphic artist has created **unity** throughout the graphic. 2

- (d) Describe how the graphic artist has created **depth** in the graphic. 2



5. (continued)

(e) Describe how the graphic artist has used **alignment** in the graphic.

2

(f) Describe how the graphic artist has created **emphasis** in the graphic.

2

[Turn over



* X 7 3 5 7 6 0 1 1 7 *

6. A company already has a large client base for its printed publications and wants to expand to an online style magazine.

(a) State two advantages to the consumer, other than cost, of an online publication when compared with a printed publication.

2

(b) The company will launch an online magazine with the option to view in a variety of languages.

Describe how this feature would be of benefit to the company.

1

(c) The online magazine will be available across a variety of electronic devices.

Explain why the choice of **typeface** is an important aspect for the company to consider when creating the online magazine.

2



* X 7 3 5 7 6 0 1 1 8 *

6. (continued)

- (d) When choosing the typeface, the graphic designers considered different **serif** and **sans serif** fonts.

Describe the main characteristics of **serif** fonts.

1

You may use sketches to support your answer.

- (e) The company stores its graphics library in the cloud.

Describe **two** advantages of cloud based storage for graphic designers.

2

[Turn over



* X 7 3 5 7 6 0 1 1 9 *

6. (continued)

MARKS

DO NOT
WRITE IN
THIS
MARGIN

Use the desktop published magazine page on the **supplementary sheet for use with question 6 (f)–(j)**, provided, to answer the following questions.

(f) Explain how the following DTP features have been used on the desktop published magazine page.

(i) Transparency

1

(ii) Colour picking

1

(g) A **drop cap** has been used on the desktop published magazine page. Explain the purpose of a **drop cap**.

2

(h) **Reverse** has been used on the desktop published magazine page. Describe the use of **reverse** in the desktop published magazine page.

2



* X 7 3 5 7 6 0 1 2 0 *

6. (continued)

- (i) The graphic designer has used different types of **justification** on the desktop published magazine page.

Explain why the designer has chosen to do this for the main body text.

1

- (j) **Line** has been used on the desktop published magazine page.

Describe how the use of **line** has been used to enhance the desktop published magazine page.

2

[END OF QUESTION PAPER]



* X 7 3 5 7 6 0 1 2 1 *

MARKS

DO NOT
WRITE IN
THIS
MARGIN

ADDITIONAL SPACE FOR ANSWERS



* X 7 3 5 7 6 0 1 2 2 *

MARKS

DO NOT
WRITE IN
THIS
MARGIN

ADDITIONAL SPACE FOR ANSWERS



* X 7 3 5 7 6 0 1 2 3 *

ACKNOWLEDGEMENTS

Question 3 (a) – EPSTOCK/Shutterstock.com
Wanzer/Shutterstock.com

Question 3 (b) – alexandre zveiger/Shutterstock.com



* X 7 3 5 7 6 0 1 2 4 *