

FOR OFFICIAL USE



National  
Qualifications  
2019

Mark

**X835/76/01**

**Graphic Communication**

TUESDAY, 21 MAY

1:00 PM – 3:30 PM



\* X 8 3 5 7 6 0 1 \*

Fill in these boxes and read what is printed below.

Full name of centre

Town

Forename(s)

Surname

Number of seat

Date of birth

Day

Month

Year

Scottish candidate number

**Total marks — 90**

Attempt ALL questions.

All dimensions are in mm.

All technical sketches and drawings use third angle projection.

You may use rulers, compasses or trammels for measuring.

In all questions you may use sketches and annotations to support your answer if you wish.

Write your answers clearly in the spaces provided in this booklet. Additional space for answers is provided at the end of this booklet. If you use this space you must clearly identify the question number you are attempting.

Use **blue** or **black** ink.

Before leaving the examination room you must give this booklet to the Invigilator; if you do not, you may lose all the marks for this paper.



\* X 8 3 5 7 6 0 1 0 1 \*

Downloaded free from <https://sqa.my/>

1. Graphics of a new blender are shown below in Figures 1 and 2.

Figure 1

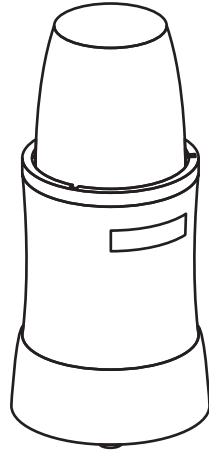

Figure 2



(a) Describe two illustration/3D rendering techniques applied to produce the realistic looking graphic shown in Figure 2.

2

---

---

---

---

(b) An alternative design is shown below for the plastic cup component. The CAD technician decides to produce this component in two stages.



Alternative cup design



## 1. (b) (continued)

- (i) You must use the additional information provided on the **supplementary sheet for use with question 1 (b) (i)** to answer this question.

Describe, using 3D CAD modelling techniques, how the technician would complete **Stage 1** as shown in the working drawings.

6

You may use sketches to support your answer.

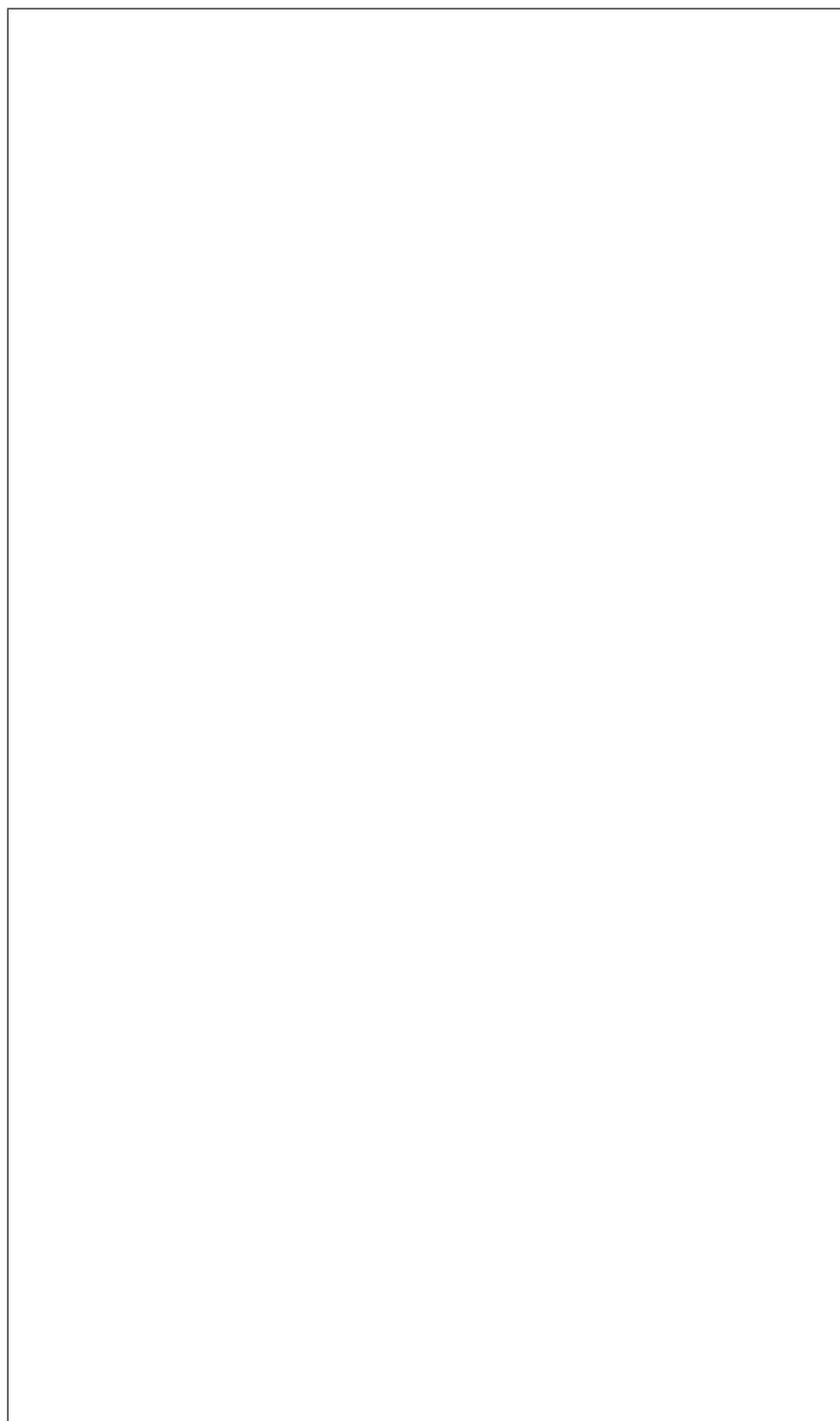

\* X 8 3 5 7 6 0 1 0 3 \*

## 1. (b) (continued)

- (ii) You must use the additional information provided on the **supplementary sheet for use with question 1 (b) (ii)** to answer this question.

The CAD technician adds additional features to allow the lid to lock into position, shown in red in **Stage 2**.

Describe how, using only the 'revolve' 3D modelling technique, the CAD technician created the additional features.

5



\* X 8 3 5 7 6 0 1 0 4 \*

[Turn over for next question

DO NOT WRITE ON THIS PAGE



\* X 8 3 5 7 6 0 1 0 5 \*

1. (continued)

- (c) A concept design for the blade sub-assembly for the blender is produced. The two blades shown have been constrained to the pin using 3D CAD modelling software.

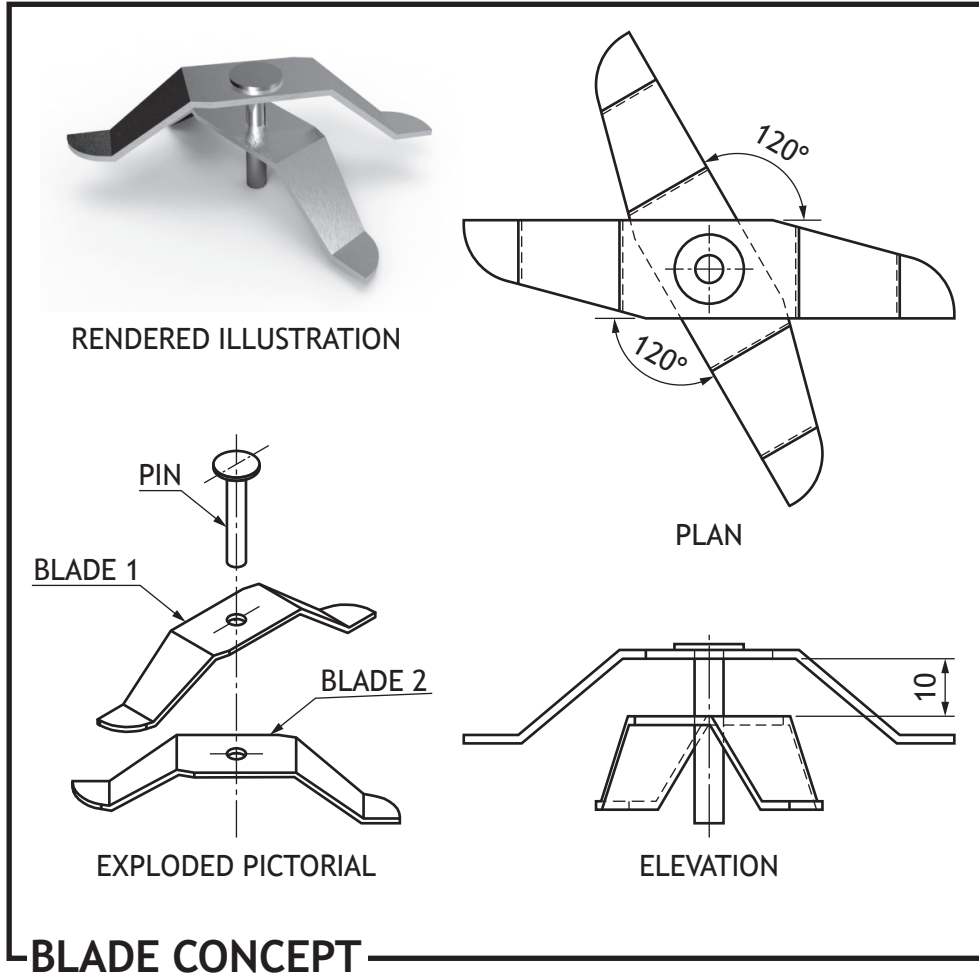

## 1. (c) (continued)

Describe the steps required to constrain the blades and pin to each other. You may annotate **Figure 1** to help with your answer.

4

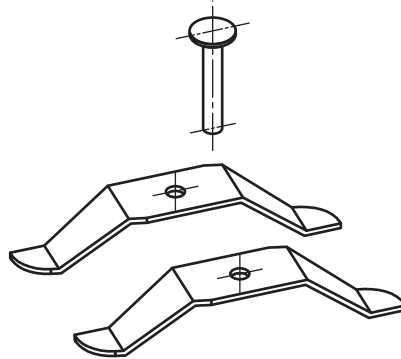

Figure 1



\* X 8 3 5 7 6 0 1 0 7 \*

2. An incomplete enlarged sectional view of a wheel assembly is given below. Using the information provided on the **supplementary sheet for use with question 2**, complete the sectional view by adding appropriate hatching.

4

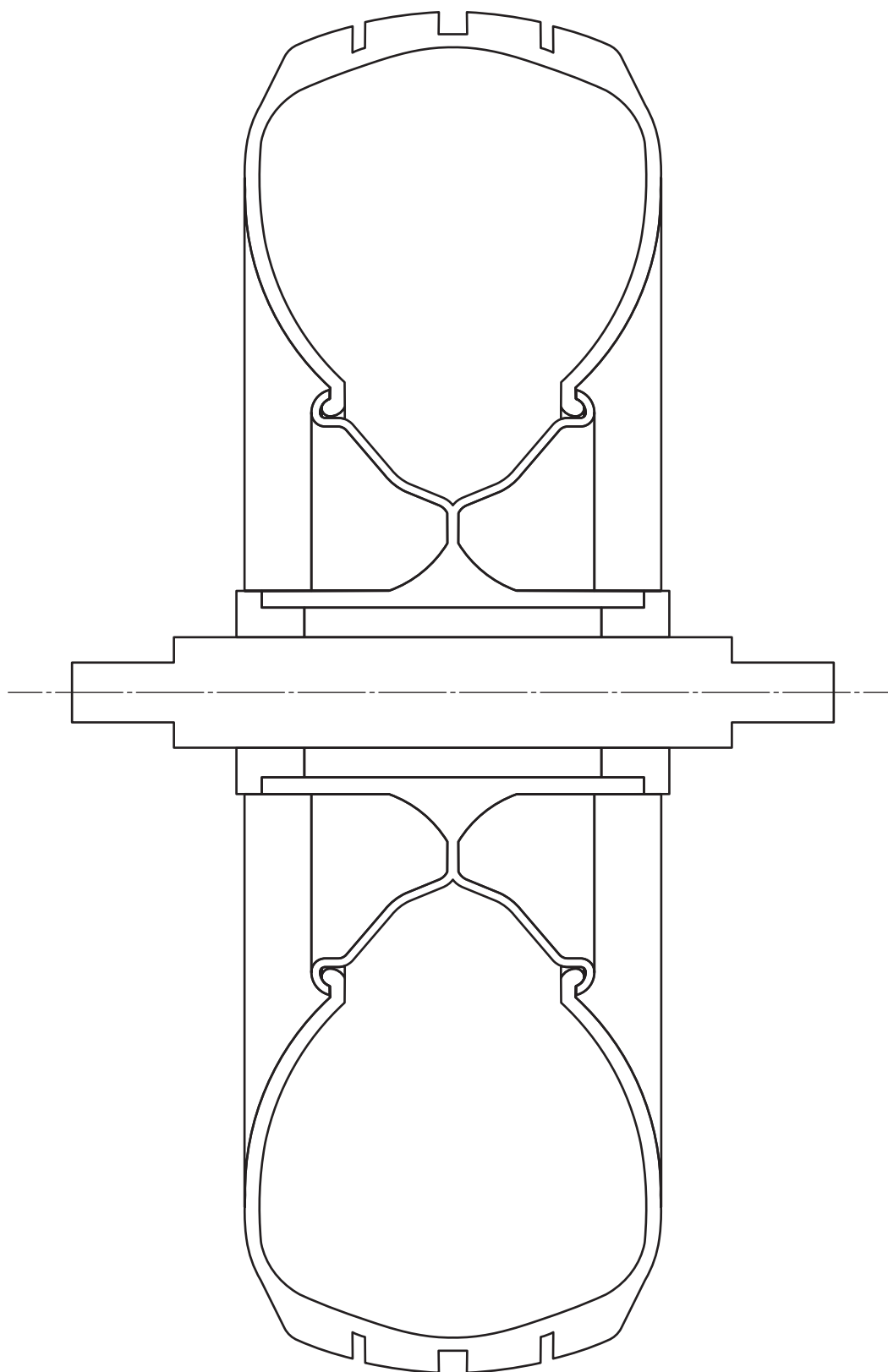

SECTION A-A



\* X 8 3 5 7 6 0 1 0 8 \*



3. A graphic designer is producing content for Scotrock, a new Scottish music festival. The logo designs below are exported as **vector** files.

Version 1

Version 2



(a) (i) Describe **two** advantages of exporting the logo shown in the **vector** format, as opposed to **raster**. 2

---



---



---



---

(ii) State the name of a **vector** file extension which the logo could be exported as. 1

---

(iii) The graphic design company operate a **paperless office**. Describe **two** advantages for the company of operating a paperless office. **Do not** include environmental benefits from reduced paper. 2

---



---



---



---

[Turn over





A draft graphic for the festival security passes is shown above.

- (b) (i) Describe two instances where the designer has used **line** to enhance the layout of the graphic. 2

---

---

---

---

- (ii) Describe two instances where the designer has used **alignment** in the graphic. 2

---

---

---

---

- (iii) Explain how the designer has used **balance** in the graphic. 2

---

---

---

---



3. (b) (continued)

MARKS

DO NOT  
WRITE IN  
THIS  
MARGIN

- (iv) Describe two instances where the designer has created **contrast** in the graphic.

2

---

---

---

---

- (c) The designer presents a proposal for a bus timetable design as shown below.



- (i) State **two** advantages of using a **sited environment** when presenting desktop publishing work to clients.

2

---

---

---

---

- (ii) The festival organisers decide to use digital screens to display the bus timetable instead of printing them. Describe **three** advantages to the festival organisers of using digital screens over traditional printed timetables.

3

---

---

---

---

---



\* X 8 3 5 7 6 0 1 1 1 \*

3. (continued)

MARKS

DO NOT  
WRITE IN  
THIS  
MARGIN

(d) You must use the graphic provided on the **supplementary sheet for use with question 3 (d)** to answer this question.

(i) Describe how the designer has used **texture** to enhance the impact of the graphic.

2

---

---

---

---

(ii) Describe two ways the designer has used **depth** within the publication.

2

---

---

---

---

(iii) Describe two ways the designer has used **emphasis** within the publication.

2

---

---

---

---

(iv) Describe two ways the designer has used **unity** within the publication.

2

---

---

---

---



\* X 8 3 5 7 6 0 1 1 2 \*

3. (d) (continued)

- (v) Explain two ways the designer has used **grid structure** within the publication.

2

---



---



---



---

The layout was produced using layers in desktop publishing software.



- (vi) Describe **two** advantages to the graphic designer of using layers to produce this layout.

2

---



---



---



---

[Turn over



\* X 8 3 5 7 6 0 1 1 3 \*

4. Parts for a retractable kickstand for a scooter are shown below.

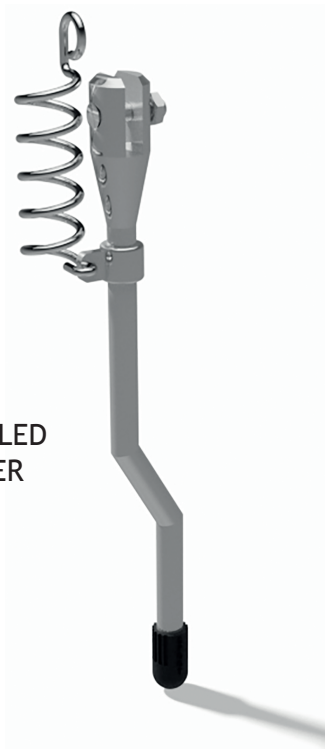

ASSEMBLED  
RENDER

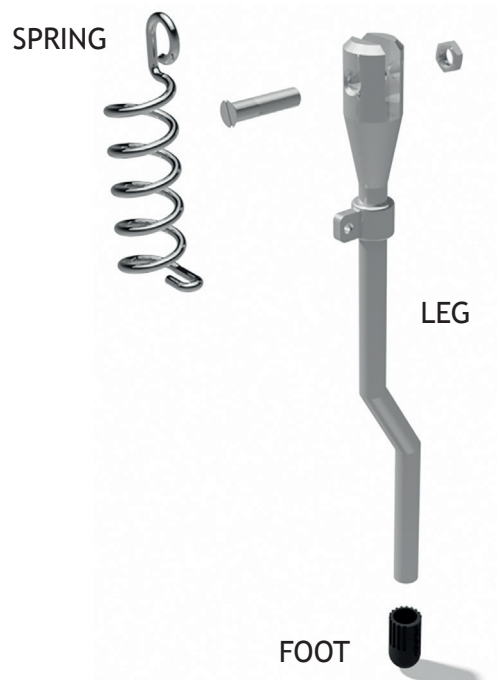

SPRING

LEG

FOOT

EXPLODED  
RENDER



\* X 8 3 5 7 6 0 1 1 4 \*

4. (continued)

MARKS  
DO NOT  
WRITE IN  
THIS  
MARGIN

- (a) The spring was modelled as a separate component using 3D CAD.  
Describe the 3D CAD modelling technique used to model the spring.  
You must make reference to the dimensions given.  
You may use sketches to illustrate your answer.

3

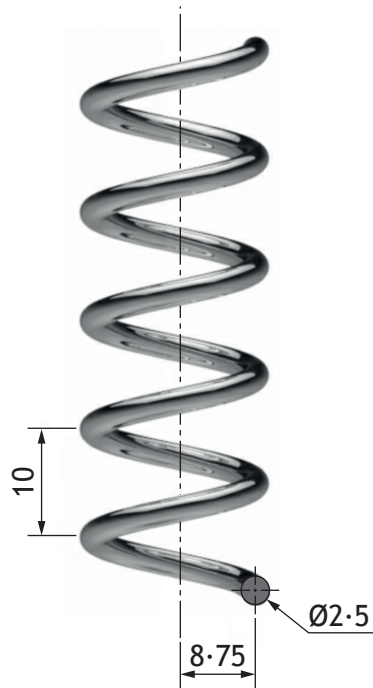

Blank area for the student's answer.



4. (continued)

MARKS DO NOT WRITE IN THIS MARGIN

- (b) The leg was 3D CAD modelled as a single component.  
Describe the modelling techniques used to generate the component.  
You may use sketches to illustrate your answer.

6

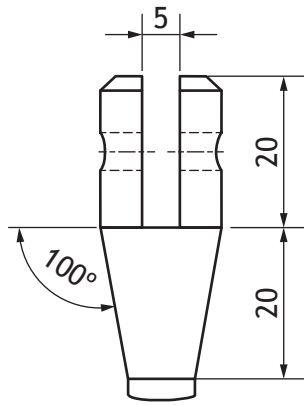

DETAIL VIEW B  
(1:1)

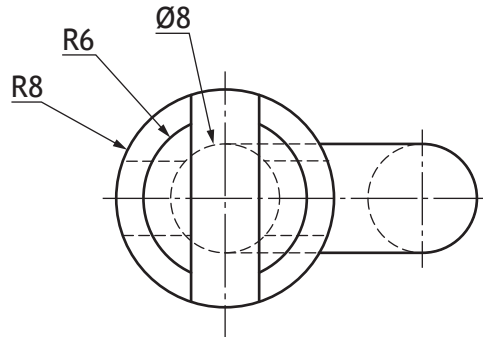

DETAIL VIEW A  
(2:1)

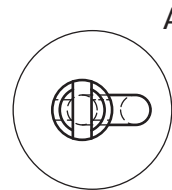

PLAN

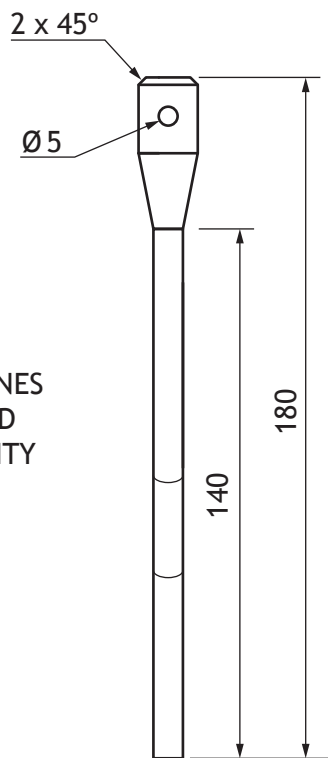

END ELEVATION

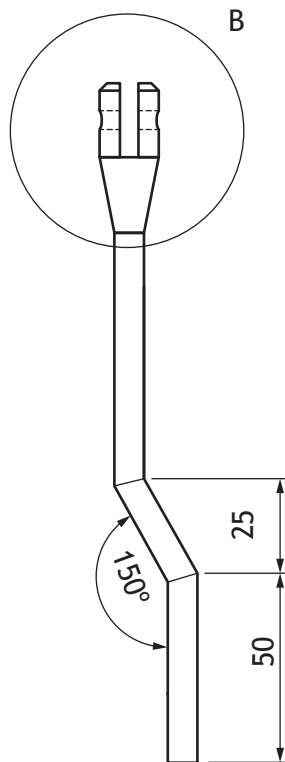

ELEVATION

SCALE 1:2

CENTRE LINES  
REMOVED  
FOR CLARITY



\* X 8 3 5 7 6 0 1 1 6 \*



4. (b) (continued)

MARKS  
DO NOT  
WRITE IN  
THIS  
MARGIN

[Empty answer box for question 4(b)]



4. (continued)

MARKS  
DO NOT  
WRITE IN  
THIS  
MARGIN

(c) The foot was 3D CAD modelled using the revolve command.

Describe the modelling edit used to complete the component from Stage 1 to Stage 2.

You may use sketches to illustrate your answer.

3

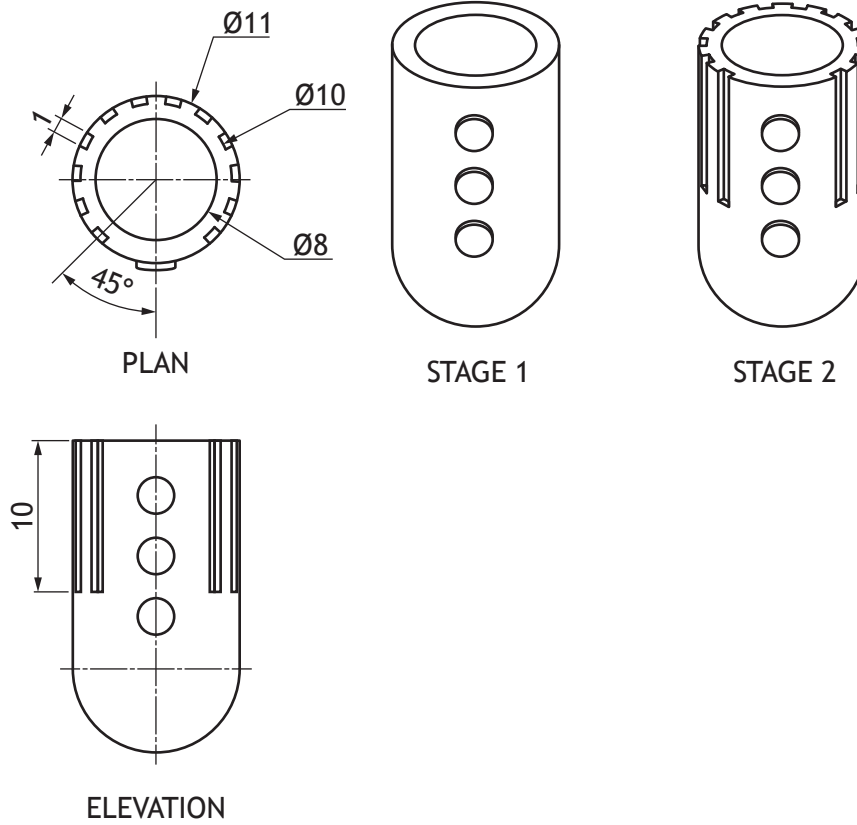

Large empty rectangular box for the student's answer.



4. (continued)

The kickstand is connected to the scooter by an M5 countersink head screw. The length of the thread is 14mm.



(d) Apply to the views below the correct British Standard conventions for

- (i) the diameter of the bolt 1
- (ii) the length of the thread 1
- (iii) the convention for a thread. 2

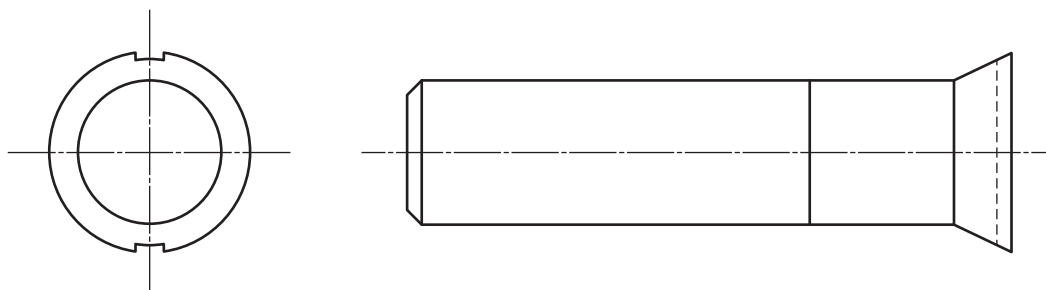

4. (continued)

- (e) The assembly technician downloads an orthographic drawing from the company network. The technician immediately notices some issues with the drawing.

Identify from the drawing, **five** errors which are not correct to British Standard conventions.

5

---



---



---



---



---

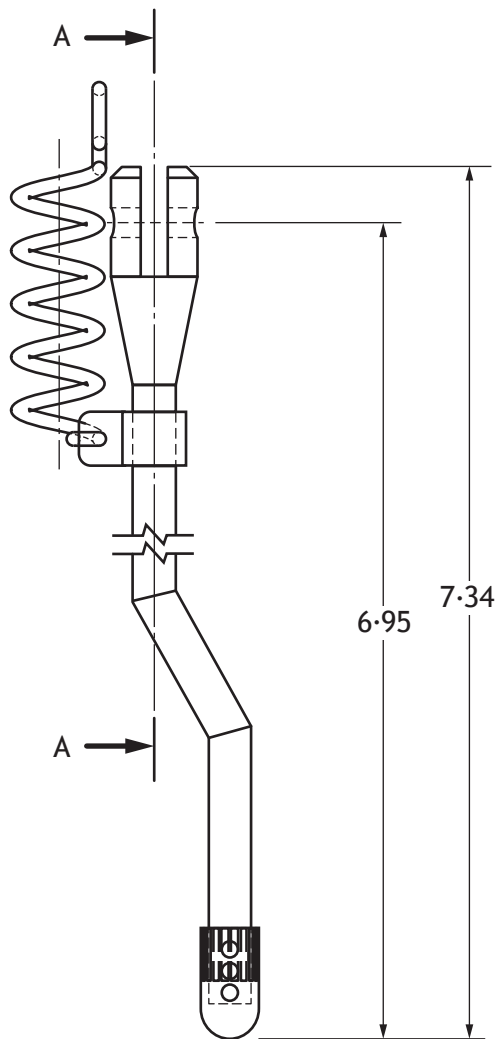

ELEVATION

DESIGNED BY M. AUTHOR	SCALE 1:2	DATE MAY 2019
KICKSTAND ORTHOGRAPHIC		
ALL DIMENSIONS ARE IN INCHES		



[Turn over for next question

DO NOT WRITE ON THIS PAGE



\* X 8 3 5 7 6 0 1 2 1 \*

5. A design company has produced a range of graphics for a music festival.

During the planning process three of the graphics were submitted.

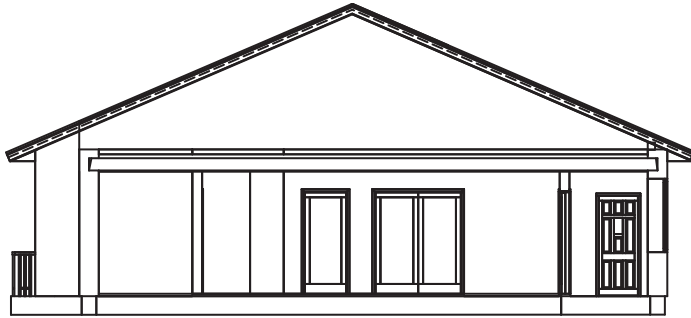

Figure 1

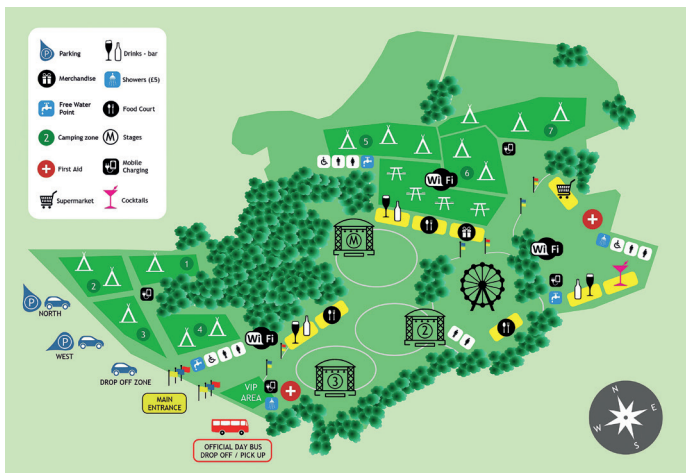

Figure 2

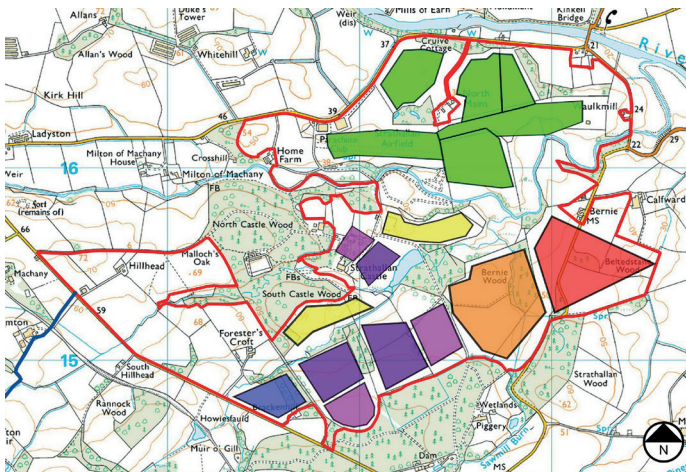

Figure 3



\* X 8 3 5 7 6 0 1 2 2 \*

5. (continued)

- (a) Explain, with reference to preliminary, production and promotional graphics, the purpose of Figures 1, 2 and 3.

3

Figure 1

---

---

---

Figure 2

---

---

---

Figure 3

---

---

---

- (b) State **three** features which should be shown on a British Standards location plan.

3

---

---

---



5. (continued)

MARKS

DO NOT WRITE IN THIS MARGIN

(c) Changes, shown in the Proposed Plan and Final Plan, were made during the planning stage. With reference to the graphics below, identify two reasons the camping areas marked with an X have been relocated.

2

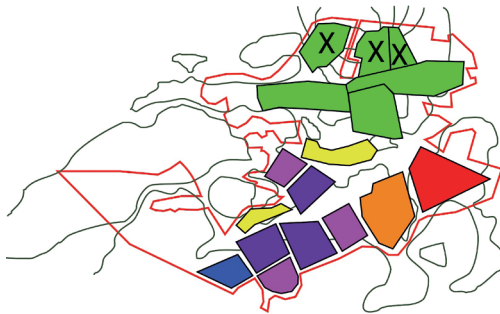

PROPOSED PLAN



FINAL PLAN

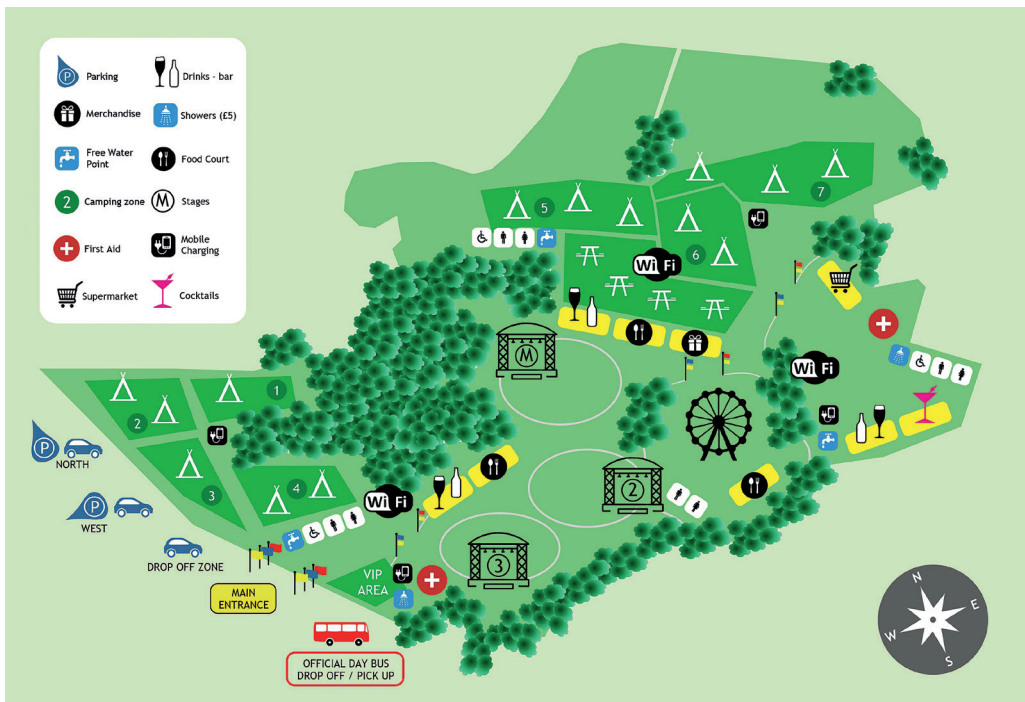

---



---



---



---



\* X 8 3 5 7 6 0 1 2 4 \*



5. (continued)

MARKS  
DO NOT  
WRITE IN  
THIS  
MARGIN

The site plan for the VIP area is shown below.

NOTE  
2 CABIN STYLE TEMPORARY BUILDINGS  
DECKING CONNECTS BOTH CABINS  
RECLAIMED TIMBER USED FOR DECKING

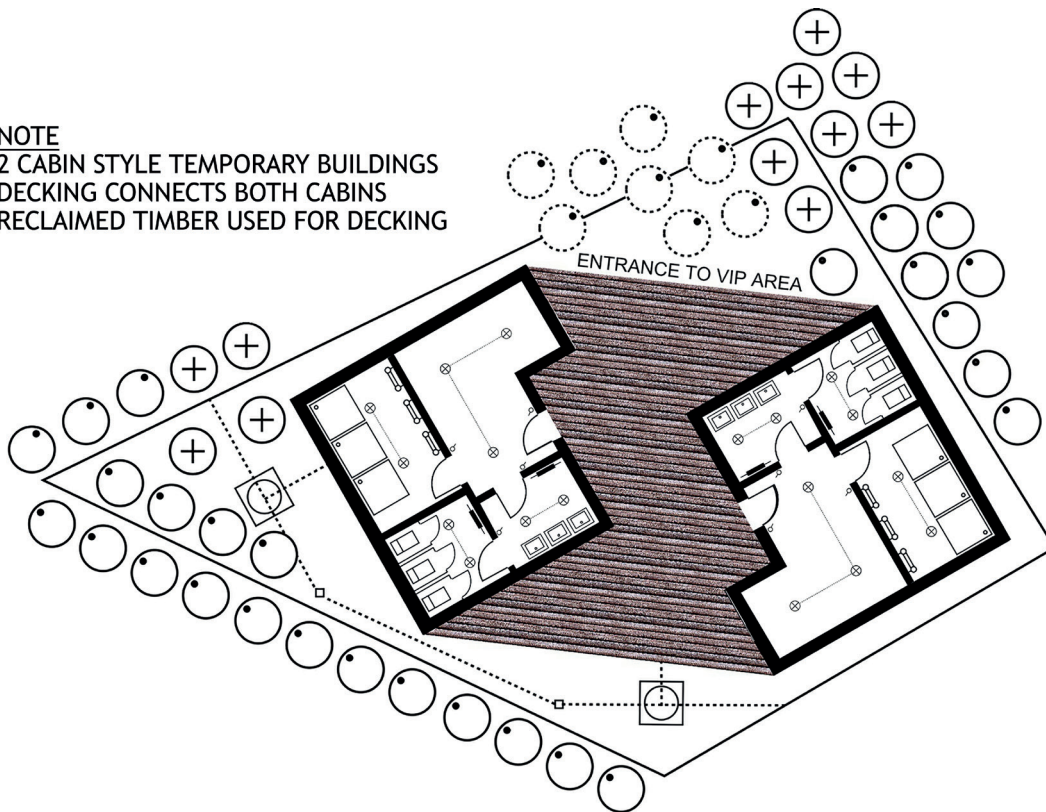

Architects had to plan around the existing environment, to create two temporary buildings and an outdoor wooden decking area.

(d) State how many existing trees are within the VIP boundary. 1

\_\_\_\_\_

(e) The site plan shows some existing trees had to be removed. State a reason why this was necessary. 1

\_\_\_\_\_  
\_\_\_\_\_

(f) Describe how the architect has considered the environmental aspect of the site. 2

\_\_\_\_\_  
\_\_\_\_\_  
\_\_\_\_\_  
\_\_\_\_\_



5. (continued)

(g) State two factors that influence the choice of scale in a floorplan.

2

---



---



---



(h) The company plans to have both a hardcopy and electronic version of the festival site plan as shown above.

State two things that the designer would have to consider when making the site plan suitable for a range of electronic devices.

2

---



---



---



---

## 5. (continued)

- (i) The company has set up a website and social media link for the event, allowing festival goers to connect with fellow attendees and those not in attendance.

Describe why the companies promoting and advertising the event may like this live link.

2

---

---

---

---

---

---

[END OF QUESTION PAPER]



\* X 8 3 5 7 6 0 1 2 7 \*

MARKS

DO NOT  
WRITE IN  
THIS  
MARGIN

ADDITIONAL SPACE FOR ANSWERS



\* X 8 3 5 7 6 0 1 2 8 \*

MARKS

DO NOT  
WRITE IN  
THIS  
MARGIN

ADDITIONAL SPACE FOR ANSWERS



\* X 8 3 5 7 6 0 1 2 9 \*

[BLANK PAGE]

DO NOT WRITE ON THIS PAGE



\* X 8 3 5 7 6 0 1 3 0 \*

[BLANK PAGE]

DO NOT WRITE ON THIS PAGE



[BLANK PAGE]

DO NOT WRITE ON THIS PAGE

*Acknowledgement of copyright*

Question 3(d) ProfyArt/shutterstock.com

Question 5(h) Oleksiy Mark/shutterstock.com



\* X 8 3 5 7 6 0 1 3 2 \*