



National
Qualifications

X840/76/12

**Human Biology
Paper 1 — Multiple choice**

Duration — 40 minutes

Total marks — 25

Attempt ALL questions.

You may use a calculator.

Instructions for the completion of Paper 1 are given on *page 02* of your answer booklet X840/76/02.

Record your answers on the answer grid on *page 03* of your answer booklet.

Space for rough work is provided at the end of this booklet.

Before leaving the examination room you must give your answer booklet to the Invigilator; if you do not, you may lose all the marks for this paper.



* X 8 4 0 7 6 1 2 *



Total marks — 25
Attempt ALL questions

1. Which row in the table describes one type of cell division?

	Type of division	Parental cell type	Cells produced
A	mitosis	germline	somatic
B	meiosis	somatic	somatic
C	meiosis	germline	gametes
D	mitosis	somatic	gametes

2. Single gene mutations involve the alteration of a DNA nucleotide sequence as a result of

- A deletion, substitution or insertion
- B duplication, insertion or substitution
- C duplication, substitution or inversion
- D deletion, inversion or translocation.

3. Personalised medicine researchers identified three mutated sequences of mRNA.

Mutated sequence	Effects of mutation
AUUG	non-harmful
ACUU	harmful
ACUG	non-harmful

A drug was designed to bind to the mutated mRNA preventing its harmful effects. Which of the following DNA sequences would be found in individuals who could be prescribed this drug as part of their treatment?

- A CGACUUC
- B TAACGAT
- C GCTGAAT
- D TCTTGAC

4. This metabolic pathway is regulated by feedback inhibition.

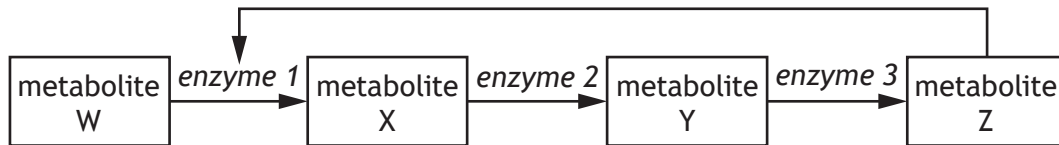

Which of the following would occur if a mutation caused enzyme 3 to be non-functional?

- A Metabolite Z would inhibit enzyme 1
- B Metabolite Z would increase in concentration
- C Metabolite Y would not be converted to metabolite Z
- D Metabolite W would not be converted to metabolite X

[Turn over

5. Three stages of respiration are listed.

1. Glycolysis
2. Citric acid cycle
3. Electron transport chain

Oxygen is used in

- A stage 2 only
- B stage 3 only
- C stages 2 and 3 only
- D stages 1, 2 and 3.

6. The diagram represents part of the respiratory pathway.

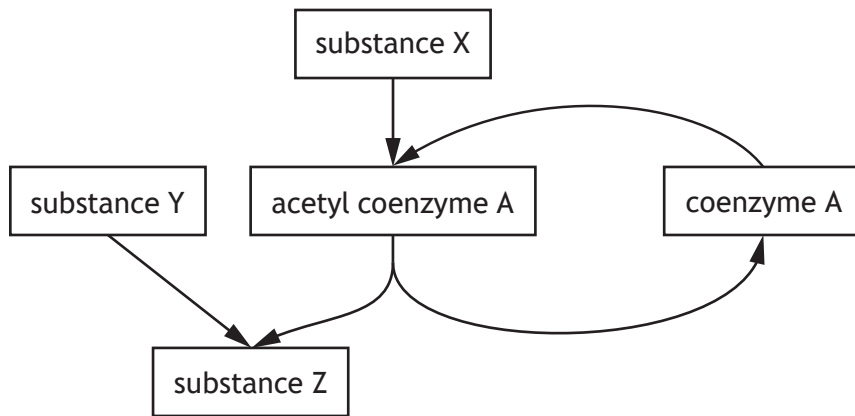

Which row in the table identifies substances X, Y and Z?

	Substance X	Substance Y	Substance Z
A	acetyl group	oxaloacetate	citrate
B	acetyl group	citrate	oxaloacetate
C	pyruvate	oxaloacetate	citrate
D	pyruvate	citrate	oxaloacetate

7. The graph shows an athlete's heart rate and blood lactate concentration while cycling for 5 minutes.

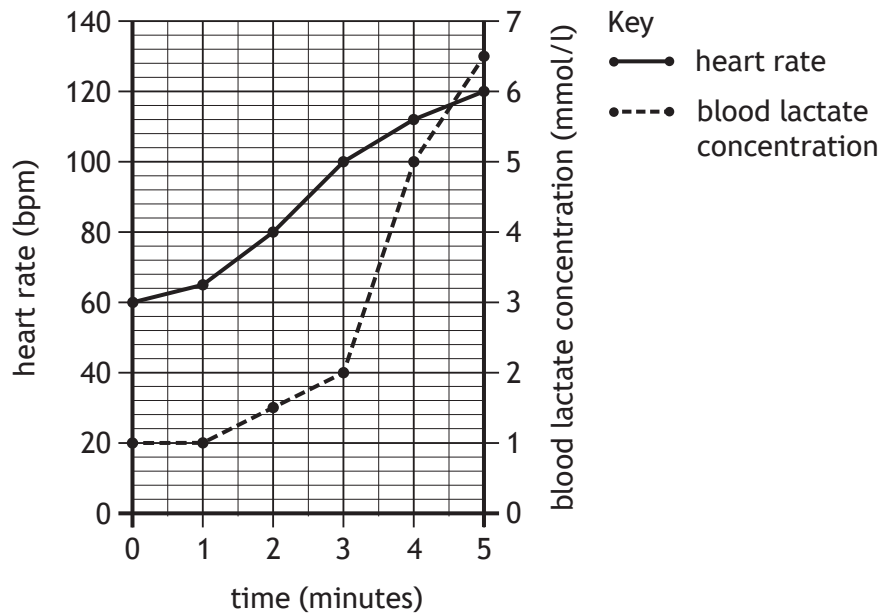

Which of the following statements is correct?

- A When the blood lactate concentration was 5 mmol/l the heart rate was 100 bpm
 - B The greatest increase in blood lactate concentration occurs between minutes 2 and 3
 - C Both heart rate and blood lactate concentration increased during every minute of exercise
 - D Over the 5 minutes, the average increase in heart rate was 12 bpm
8. A sample of leg muscle from an Olympic 100 metre sprinter was analysed. Which row in the table is most likely to indicate the results of this analysis?

	Most common muscle fibre type	Mitochondria per cell
A	fast-twitch	2000
B	slow-twitch	2000
C	fast-twitch	500
D	slow-twitch	500

[Turn over

10. Which row in the table matches a method of contraception with its effect?

	Method of contraception	Effect
A	combined oral contraceptive pill	prevents release of FSH
B	progesterone-only pill	prevents implantation
C	combined oral contraceptive pill	prevents implantation
D	progesterone-only pill	prevents release of FSH

11. The table shows information a woman used to monitor her fertility.

Date	Temperature (°C)	Consistency of cervical mucus
14 November	37.3	thick
18 November	37.3	thin
22 November	37.8	thin
26 November	37.8	thick

On which date is ovulation most likely to have occurred?

- A 14 November
- B 17 November
- C 21 November
- D 26 November

[Turn over

12. Duchenne muscular dystrophy is a sex-linked recessive condition that results in weakening of skeletal muscles over time.

An unaffected man and a carrier woman have a child.

The percentage chance that the child will have Duchenne muscular dystrophy is

- A 0%
- B 25%
- C 50%
- D 100%

13. A study was carried out into the effect of caffeine on blood pressure.

The blood pressure of four individuals was measured before and after consumption of a drink containing caffeine.

The results are shown in the table.

Individual	Initial blood pressure (mmHg)	Final blood pressure (mmHg)
1	120/75	146/97
2	115/79	132/99
3	127/86	159/100
4	118/80	139/96

The average increase in systolic blood pressure was

- A 18
- B 24
- C 72
- D 96.

14. The diagram shows a section through a heart and the pathway an impulse takes through the heart muscle.

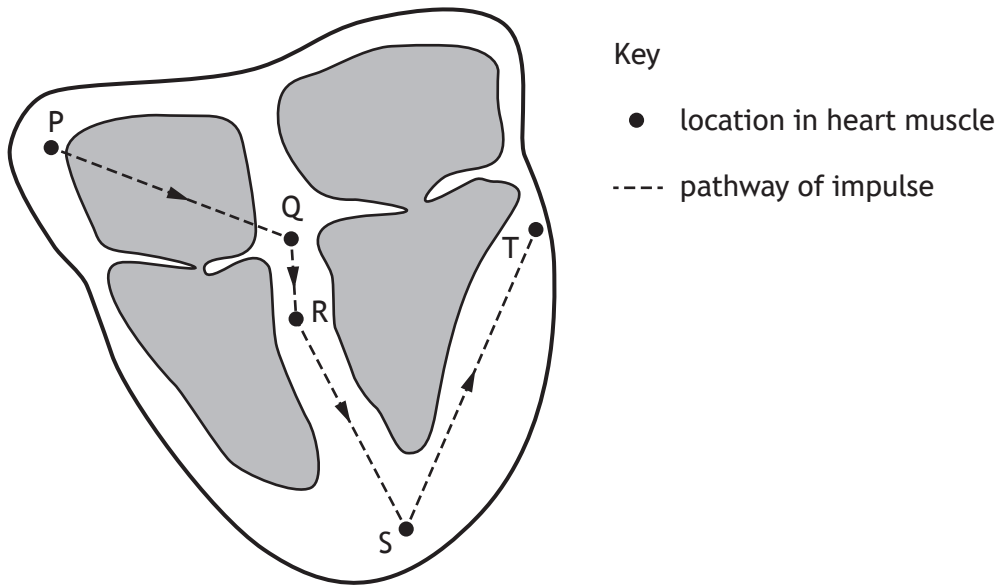

The table shows the distance and the time taken for the impulse to travel through each section of the pathway.

Section of pathway	Distance travelled (mm)	Time taken (s)
P to Q	40	0.07
Q to R	20	0.09
R to S	85	0.04
S to T	115	0.05

Through which section of the pathway does an impulse travel fastest?

- A P to Q
- B Q to R
- C R to S
- D S to T

[Turn over

15. A group of individuals took part in an investigation into the effect of a drug on their heart rate.

Which of the following procedures should have been carried out to ensure the results were valid?

- A There should have been a larger number of individuals in the group
- B The results should have been regularly recorded using a heart rate monitor
- C The investigation should have been repeated with another group of individuals
- D The activity levels of the individuals during the investigation should have been the same

16. Atheromas can rupture, damaging the endothelium and triggering the following events.

1. A thrombus forms
2. Clotting factors are released
3. Fibrinogen is converted into fibrin
4. Prothrombin is converted into thrombin

Which of the following sequences shows the order in which these events occur?

- A 1, 3, 4, 2
- B 2, 4, 3, 1
- C 2, 3, 4, 1
- D 1, 2, 4, 3

17. The table shows the result of a glucose tolerance test carried out on two individuals. One of the individuals was found to have diabetes.

Time after drinking glucose solution (minutes)	Blood glucose concentration (mmol/l)	
	Individual 1	Individual 2
0	5.5	7.5
20	7.5	12.0
40	8.0	15.0
60	7.5	15.0
80	7.0	13.5
100	6.5	12.0
120	6.0	10.5

The blood glucose concentration of the individual with diabetes would be expected to return to its initial value after a further

- A 20 minutes
 - B 40 minutes
 - C 140 minutes
 - D 160 minutes.
18. A neural pathway in which neurons later in the pathway link with earlier neurons is a
- A diverging pathway
 - B converging pathway
 - C summation pathway
 - D reverberating pathway.

[Turn over

19. The left cerebral hemisphere controls speech production and processes information from the right eye while the right cerebral hemisphere processes information from the left eye.

An individual whose corpus callosum had been cut for medical reasons took part in a study. They had to press their forehead against a barrier so that their left eye could only see to the left of the barrier and their right eye to the right of the barrier.

The diagram shows the setup of the study.

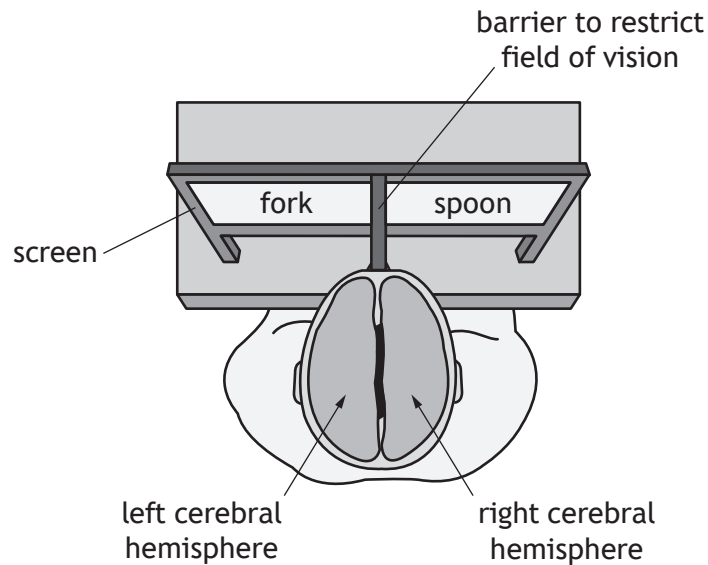

The individual was asked to look straight ahead and then the words 'fork' and 'spoon' appeared briefly on the screen as shown. The individual was then asked to say what they had just seen.

The individual would be most likely to say

- A fork only
- B spoon only
- C nothing
- D fork and spoon.

20. A group of 18 people took part in an experiment on memory.

The table shows the number of people who could recall words from a list that had been read out to them.

Place of word in list	Number of people who could recall word
1st	18
2nd	18
3rd	18
4th	13
5th	12
6th	10
7th	12
8th	16
9th	17
10th	18

The change in the number of people who recalled the words in the middle of the list was due to

- A chunking
- B rehearsal
- C displacement
- D elaborative encoding.

21. Drug addiction affects neurotransmitter receptors by

- A increasing their sensitivity as a result of exposure to antagonists
- B decreasing their sensitivity as a result of exposure to antagonists
- C increasing their sensitivity as a result of exposure to agonists
- D decreasing their sensitivity as a result of exposure to agonists.

[Turn over

22. Parkinson's disease results in reduced levels of the neurotransmitter dopamine in the brain.

Which of the following drugs would be a suitable treatment for this disease?

- A Dopamine agonists
- B Dopamine inhibitors
- C Dopamine antagonists
- D Dopamine reuptake activators

23. Cytokines act at the site of infection by

- A signalling the production of phagocytes
- B stimulating phagocytes to release antibodies
- C carrying out phagocytosis to engulf bacteria
- D causing the accumulation of phagocytes.

24. The herd immunity threshold for measles in a particular population is 90%.

The table shows the number of individuals vaccinated within the population in a four year period.

Year	Population	Number of individuals vaccinated
2012	300 000	270 000
2013	310 000	280 000
2014	325 000	285 000
2015	335 000	310 000

A measles outbreak would most likely have occurred in

- A 2012
- B 2014
- C 2012 and 2014
- D 2012, 2013 and 2015.

25. Cryptosporidium is a parasite that causes individuals to suffer from severe diarrhoea. The graph shows details of the number of cases of cryptosporidium infection in a country in 2016.

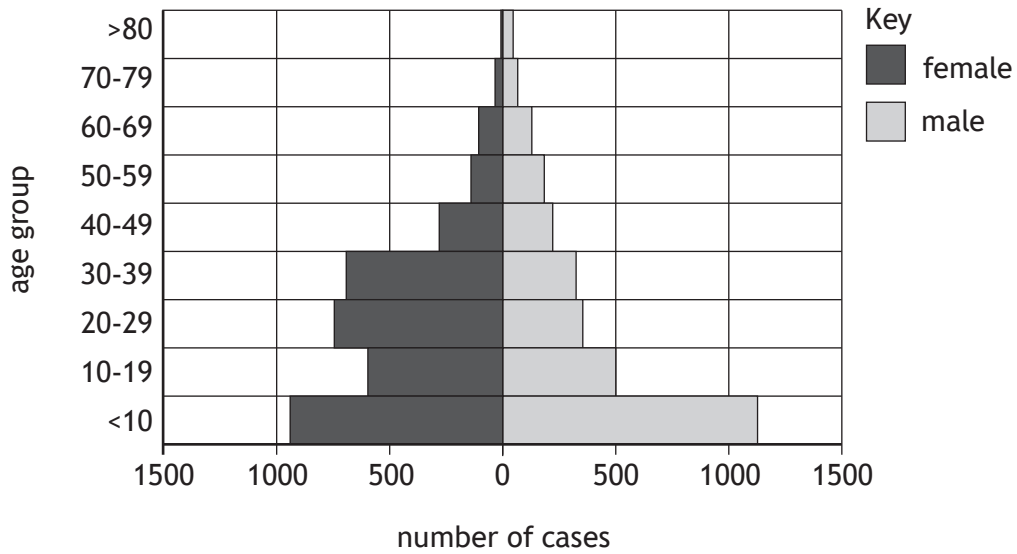

What conclusion can be drawn from the graph?

- A In all age groups there are fewer cases in females than males
- B In all age groups there are fewer cases in males than females
- C As the age group of females increases the number of cases always decreases
- D As the age group of males increases the number of cases always decreases

[END OF QUESTION PAPER]

FOR OFFICIAL USE



--	--	--	--	--	--

National Qualifications

Mark

--

X840/76/01

**Human Biology
Paper 2**

Duration — 2 hours 20 minutes



Fill in these boxes and read what is printed below.

Full name of centre

--

Town

--

Forename(s)

--

Surname

--

Number of seat

--

Date of birth

Day

--	--

Month

--	--

Year

--	--

Scottish candidate number

--	--	--	--	--	--	--	--	--	--

Total marks — 95

Attempt ALL questions.

You may use a calculator

Question 14 contains a choice.

Write your answers clearly in the spaces provided in this booklet. Additional space for answers and rough work is provided at the end of this booklet. If you use this space you must clearly identify the question number you are attempting. Any rough work must be written in this booklet. Score through your rough work when you have written your final copy.

Use **blue** or **black** ink.

Before leaving the examination room you must give this booklet to the Invigilator; if you do not, you may lose all the marks for this paper.



Total marks — 95
 Attempt ALL questions
 Question 14 contains a choice

1. The diagram shows a range of cell types produced by blood stem cells.

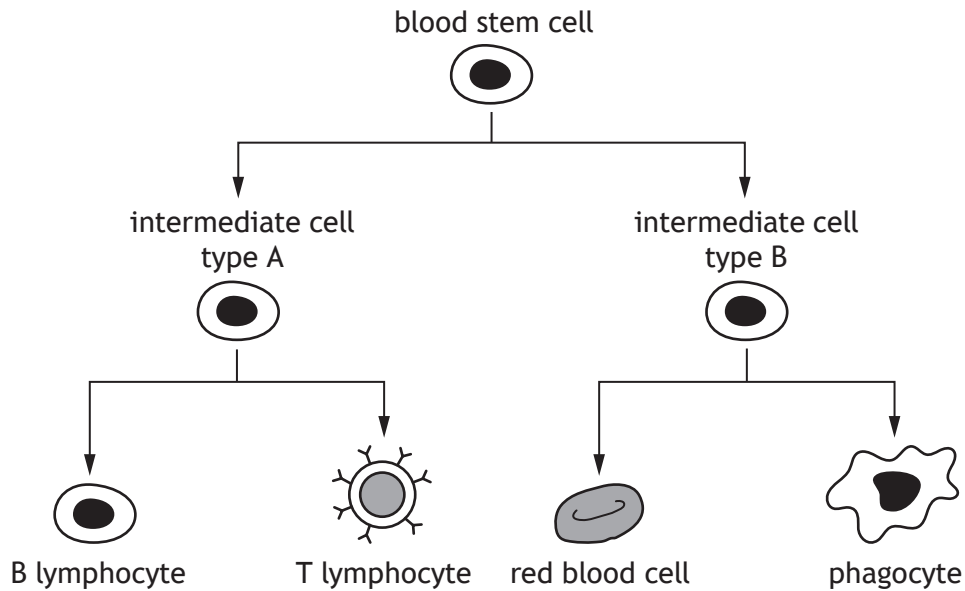

(a) State the location of blood stem cells in the body. 1

(b) Use information in the diagram to explain why blood stem cells are described as tissue stem cells. 1

(c) Describe one therapeutic use and one research use of stem cells. 2

Therapeutic use _____

Research use _____



2. (a) The tables show the number of deaths from some common types of cancer in males and females in Scotland in 2016.

The tables also show the percentage change in the number of deaths since 2007 due to these types of cancer.

MARKS
DO NOT
WRITE IN
THIS
MARGIN

Table 1 Males

Type of cancer	Number of deaths in 2016	Change in number of deaths since 2007 (%)
Lung	2036	-24.3
Prostate	986	-6.2
Bowel	884	-15.1
Head and neck	377	+17.1
Liver	375	+47.4
Bladder	311	-7.7
Stomach	273	-32.8
Other	3085	—
Total	8327	-12.4

Table 2 Females

Type of cancer	Number of deaths in 2016	Change in number of deaths since 2007 (%)
Lung	2033	-7.1
Breast	946	-17.2
Bowel	803	-5.8
Ovary	400	
Liver	256	+92.8
Uterus		+59.1
Bladder	166	-8.5
Other	2138	—
Total	7774	-7.5

- (i) State which type of cancer in males shows the largest percentage decrease in the number of deaths since 2007.

1



* X 8 4 0 7 6 0 1 0 4 *

2. (a) (continued)

MARKS
DO NOT
WRITE IN
THIS
MARGIN

(ii) Calculate the number of female deaths from cancer of the uterus in 2016.

1

Space for calculation

(iii) There were 500 deaths from cancer of the ovary in 2007.

Calculate the percentage decrease in the number of deaths due to this type of cancer since 2007.

1

Space for calculation

_____ %

(iv) Using information from Table 1, explain why it may **not** be correct to state that there were no male deaths from breast cancer in 2016.

1

(v) Suggest a reason for the difference in the percentage change in the number of deaths due to lung cancer between males and females since 2007.

1

(b) Since 2007, all people in Scotland between the ages of 50 and 74 have been offered regular screening for bowel cancer.

Suggest how this screening programme may have contributed to the percentage decrease in the number of deaths from bowel cancer between 2007 to 2016.

1

(c) Cancer cells may divide excessively to form a tumour.

Describe how secondary tumours can then form from this tumour.

1



* X 8 4 0 7 6 0 1 0 5 *

3. (a) The diagram represents a section of DNA from a chromosome undergoing replication.

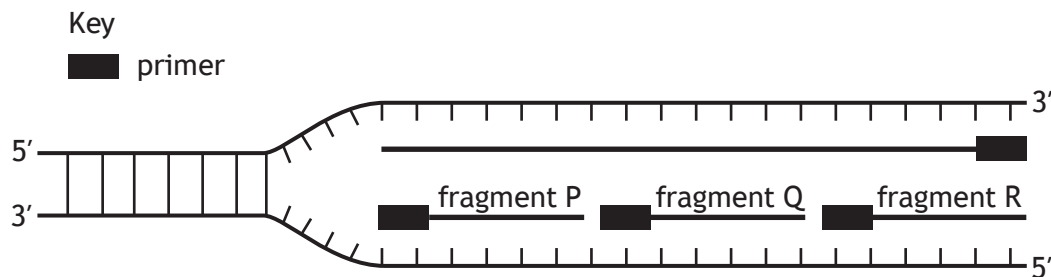

(i) Describe the role of primers in allowing DNA replication to start. 2

(ii) Fragments P, Q and R are joined together to replicate the lagging strand.
 Explain why the lagging strand is replicated in fragments. 1

(iii) Identify the first fragment produced from the lagging strand. 1

(iv) Name the enzyme that joins the fragments together. 1



3. (continued)

(b) The graph shows changes in the temperature of a reaction tube during one cycle of the polymerase chain reaction (PCR).

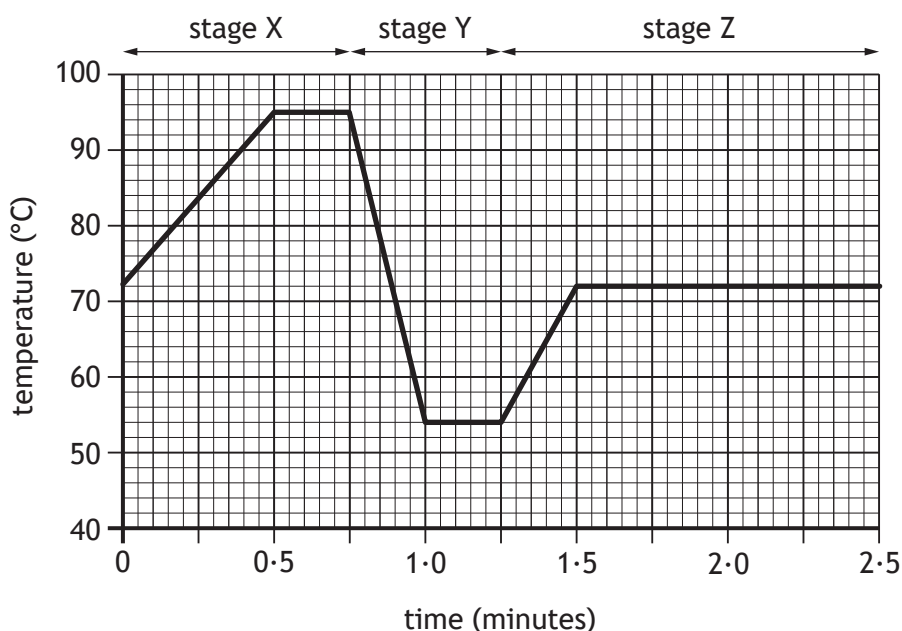

(i) Before the reaction began there were 1000 copies of a DNA fragment in the reaction tube.

Calculate the time it would take until there were at least one million copies of this DNA fragment present.

1

Space for calculation

_____ minutes

(ii) Explain why the reaction tube is heated in stage X.

1

(iii) Explain why the reaction tube is cooled in stage Y.

1



4. An investigation was carried out to show the effect of two different inhibitors on the rate of a reaction, catalysed by an enzyme.

The graph shows the results of this investigation.

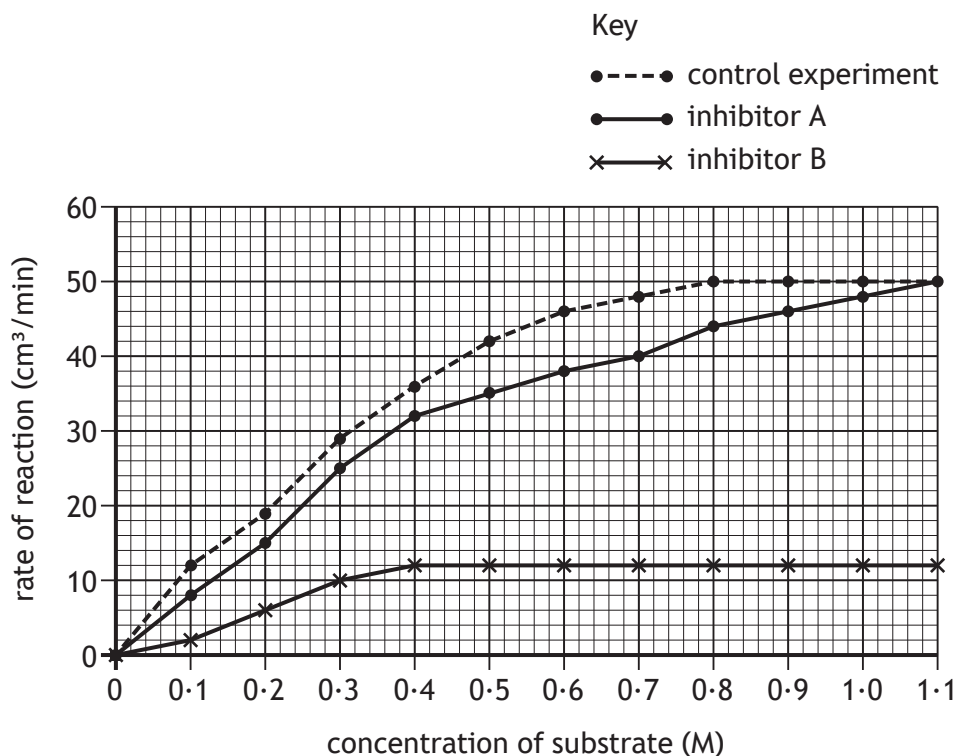

- (a) Name the substances present in the control experiment. 1

- (b) Use the information in the graph to select which inhibitor is non-competitive and give a reason for your choice. 1

Inhibitor _____

Reason _____

- (c) Calculate the decrease in the rate of reaction caused by inhibitor B at 0.7 M substrate concentration. 1

Space for calculation

_____ cm³/min



4. (continued)

- (d) Predict the rate of reaction using inhibitor A at a substrate concentration of 1.2 M.

1

_____ cm³/min

- (e) The diagram represents a reaction in a metabolic pathway.

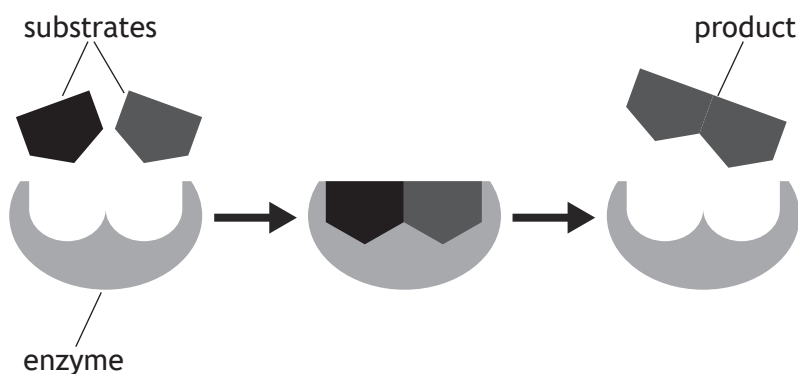

- (i) Name the type of reaction shown in the diagram and give a reason for your answer.

2

Type of reaction _____

Reason _____

- (ii) Describe the role of induced fit in this enzyme-catalysed reaction.

2

[Turn over



5. Proton pumps are proteins found in the membranes of cells lining the stomach.

Protons are hydrogen ions that increase acidity.

An investigation was carried out to determine the effect of a drug that acts as a proton pump inhibitor.

The inhibitor drug is usually given to people who produce too much stomach acid.

The diagrams show how the drug works.

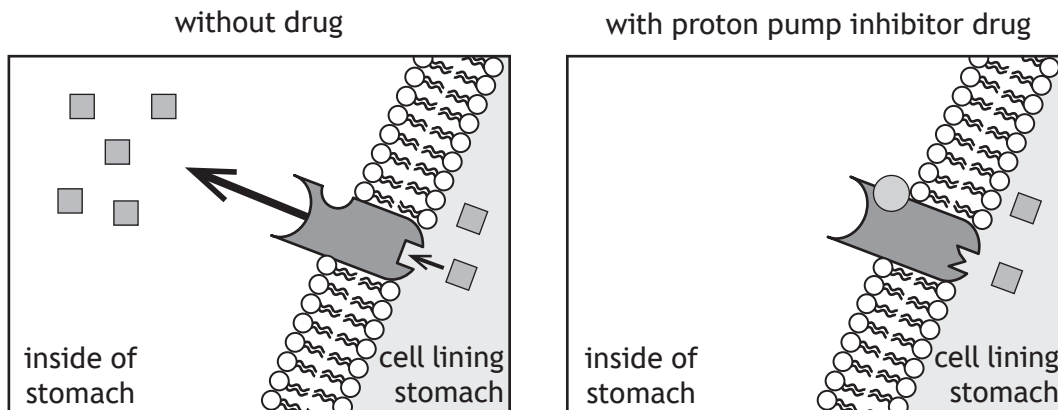

Key

■ proton (hydrogen ion)



proton pump



proton pump inhibitor drug

- (a) Use the diagrams to describe how this proton pump inhibitor drug works. 2

- (b) A large number of individuals who produced too much acid in their stomachs were divided into two groups.

Individuals in Group A consumed a tablet containing the proton pump inhibitor drug at the start of the investigation.

Individuals in Group B formed the control group.

- (i) State how the individuals would be assigned to each group in order to reduce bias. 1



5. (b) (continued)

MARKS

DO NOT WRITE IN THIS MARGIN

- (ii) The average acid production of each group was measured every two hours over an eight hour period and the results are shown in the graph.

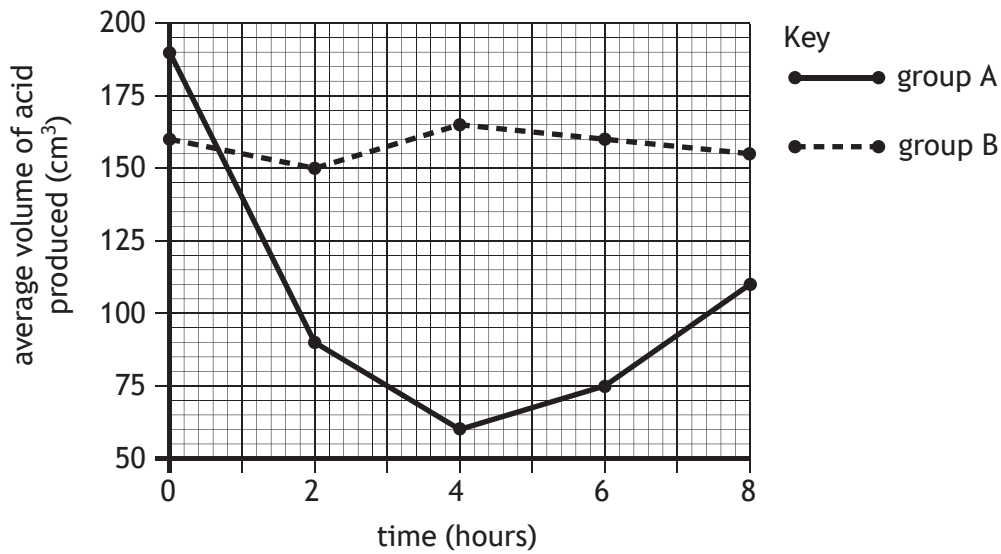

Use data from the graph to describe the changes that occurred in the acid production of group A during the investigation.

2

- (iii) A student analysed these results and concluded that the drug was most effective at four hours.

Explain why this conclusion may **not** be correct.

1

- (c) Apart from their role in making the stomach more acidic, hydrogen ions are required for ATP synthesis in the mitochondria.

Describe the role of hydrogen ions in ATP synthesis.

2



* X 8 4 0 7 6 0 1 1 1 *

6. The graph shows changes in a female's FSH and LH concentrations over 36 days.

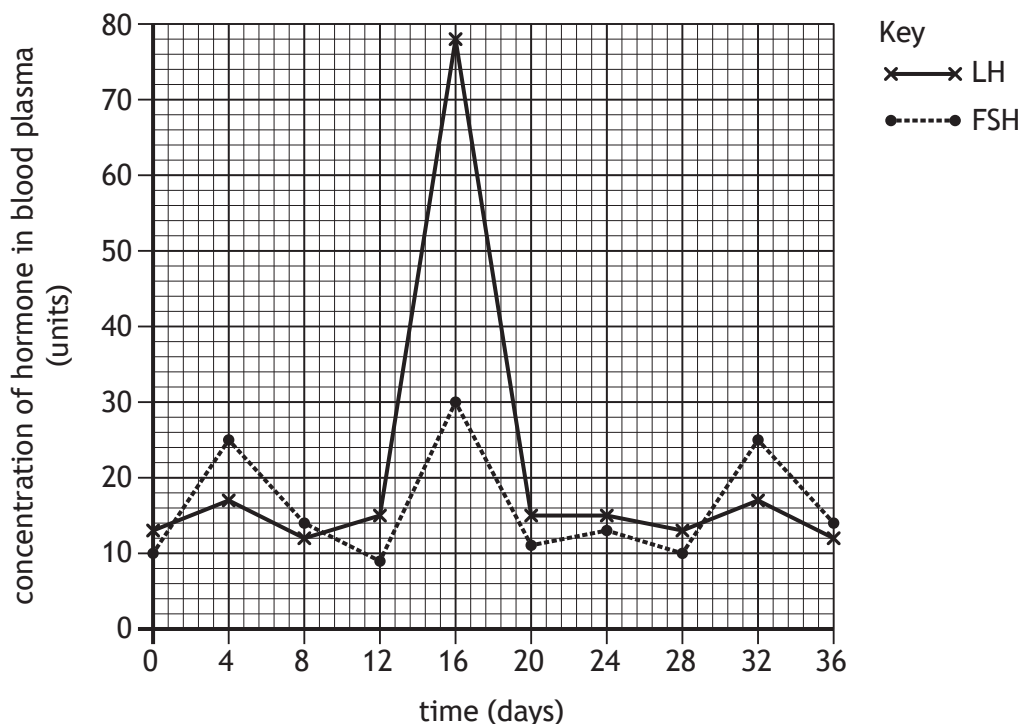

- (a) Name the part of the brain that produces the releaser hormone, which triggers FSH and LH secretion at puberty.

1

- (b) Describe **one** role of FSH in females.

1

- (c) Calculate the increase that occurs in the concentration of LH between day 12 and day 16.

1

Space for calculation

_____ units



* X 8 4 0 7 6 0 1 1 2 *

6. (continued)

- (d) A surge in LH triggers ovulation.

Name the phase of the menstrual cycle that takes place after ovulation.

1

- (e) Describe how a decrease in LH concentration leads to menstruation.

2

- (f) Explain how the information in the graph indicates that this female has cyclical fertility.

1

- (g) Explain one way that fertility drugs stimulate ovulation.

1

[Turn over



* X 8 4 0 7 6 0 1 1 3 *

7. Familial hypercholesterolaemia (FH) is a genetic disorder caused by a **dominant** allele that raises blood cholesterol concentrations.

(a) The diagram shows the family history of this condition over three generations.

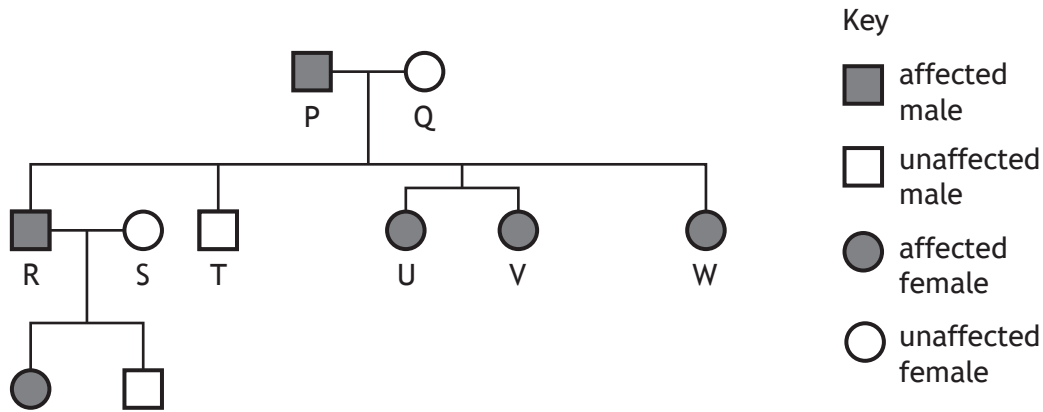

(i) FH is caused by a mutation on chromosome 19.

State the name for a chromosome that is **not** a sex chromosome.

1

(ii) Referring to individuals labelled in the diagram, describe how the inheritance pattern shown indicates that this condition cannot be caused by a sex-linked allele.

1

(iii) If daughter W had a child with a man who is heterozygous, calculate the percentage chance of the child inheriting FH.

1

Space for calculation

_____ %

(iv) State the relationship between sisters U and V.

1



7. (continued)

- (b) FH results in non-functional LDL receptors.

Explain why non-functional LDL receptors can lead to an individual having high blood pressure.

2

- (c) (i) Name a type of medication used to reduce blood cholesterol concentrations.

1

- (ii) Explain the benefit of regular physical activity to individuals suffering from high blood cholesterol.

2

[Turn over



* X 8 4 0 7 6 0 1 1 5 *

8. An investigation was set up to study the effect of the intensity of exercise on cardiac output.

An individual was asked to run on a treadmill and their heart rate and stroke volume were measured.

At the start of the investigation the gradient of the treadmill was set at 0.

To increase the intensity of exercise the gradient was increased in evenly stepped stages from 0 through to 10.



Heart rate and stroke volume were measured and used to calculate the cardiac output.

- (a) (i) State **one** variable that should be kept constant during this investigation.

1

- (ii) Describe how the reliability of the results from this investigation could be increased.

1



8. (continued)

MARKS
DO NOT WRITE IN THIS MARGIN

(b) The results of this investigation are shown in the table.

Treadmill gradient	Heart rate (beats/min)	Stroke volume (cm ³)	Cardiac output (litres/min)
0	100	86	8.6
2	109	90	9.8
4	124	100	12.4
6	151	110	16.6
8	174	100	17.4
10	185		17.6

(i) Calculate the stroke volume when the treadmill gradient was set at 10.

1

Space for calculation

_____ cm³

(ii) Draw a line graph to show the effect of treadmill gradient on cardiac output.

2

(Additional graph paper, if required, can be found on page 28.)

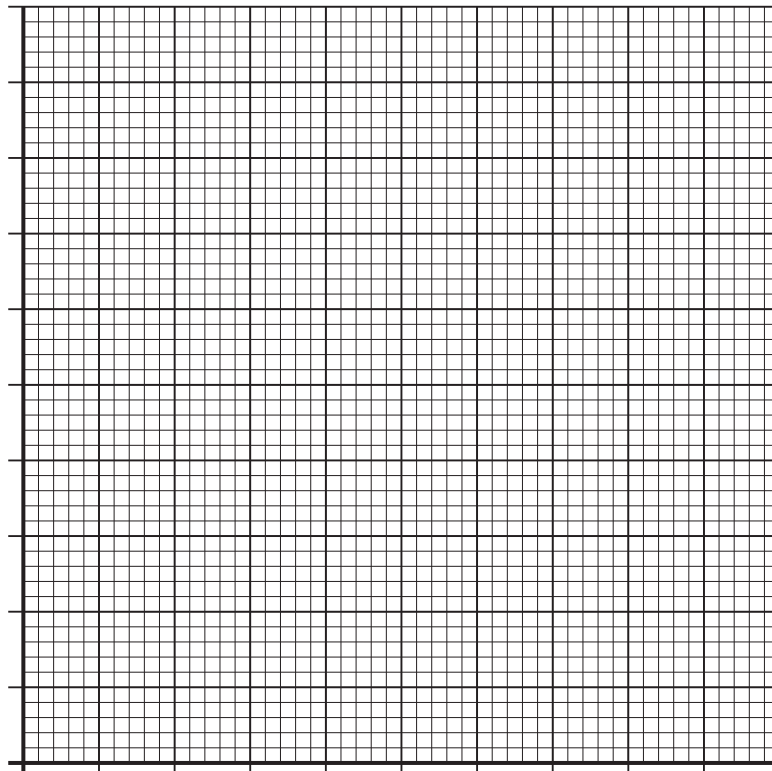

8. (b) (continued)

(iii) State a conclusion that can be drawn from the results of this investigation.

1

(c) Suggest why stroke volume was observed to decrease after treadmill gradient 6.

1



* X 8 4 0 7 6 0 1 1 8 *

9. The diagram represents a neuron from an individual who has an autoimmune disease.

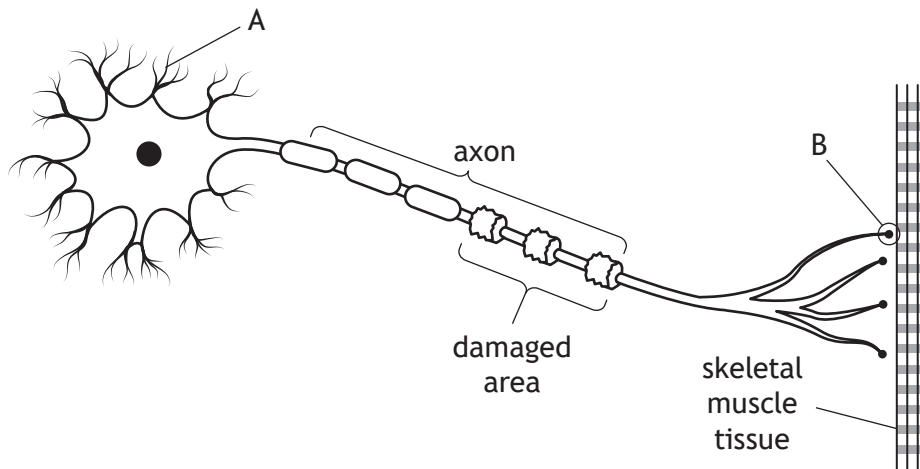

- (a) Name A and B.

2

A _____

B _____

- (b) Describe the role of the immune system in causing this autoimmune disease.

2

- (c) Explain why this individual has a loss of muscle coordination.

1

[Turn over



10. The diagram shows divisions of the nervous system.

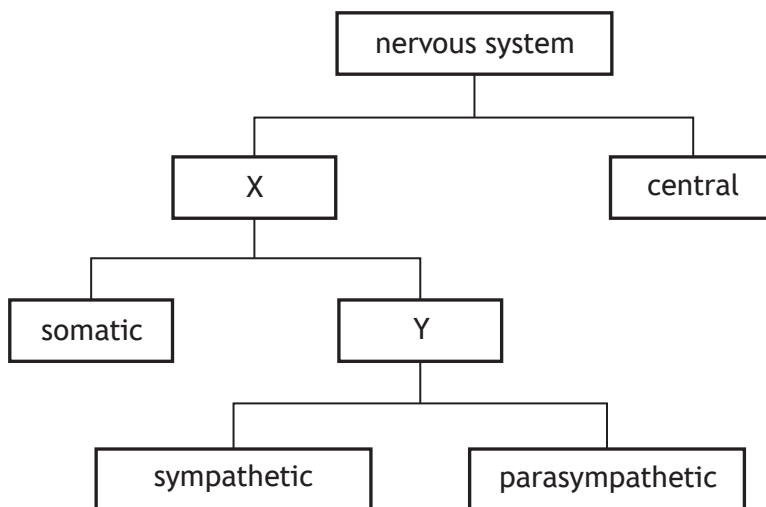

(a) Name the divisions of the nervous system labelled X and Y. 2

X _____

Y _____

(b) The somatic nervous system contains sensory neurons. Describe the function of sensory neurons. 1

(c) Describe an effect of the parasympathetic nervous system on breathing and the digestive system. 2

Breathing _____

Digestive system _____



* X 8 4 0 7 6 0 1 2 0 *

11. (a) A biology teacher was teaching a lesson about the heart.

(i) Name the level of memory involved when students first saw and heard information on the heart.

1

(ii) As part of the lesson, students coloured in and labelled a diagram of the heart.

Suggest how a diagram of the heart in an exam might provide a contextual cue to this activity.

1

(b) Describe **three** methods that help transfer information from short-term to long-term memory during learning.

3

[Turn over



* X 8 4 0 7 6 0 1 2 1 *

12. The number of excess winter deaths is calculated by subtracting the average number of deaths in autumn and spring from the number of deaths in winter.

(a) The table shows the number of deaths in Scotland in 2017/18.

Season	Number of deaths
autumn 2017	18 694
winter 2017/18	23 137
spring 2018	17 986

Calculate the number of excess winter deaths in 2017/18.

1

Space for calculation

(b) The graph shows the number of excess winter deaths in Scotland and England between 2013/14 and 2016/17.

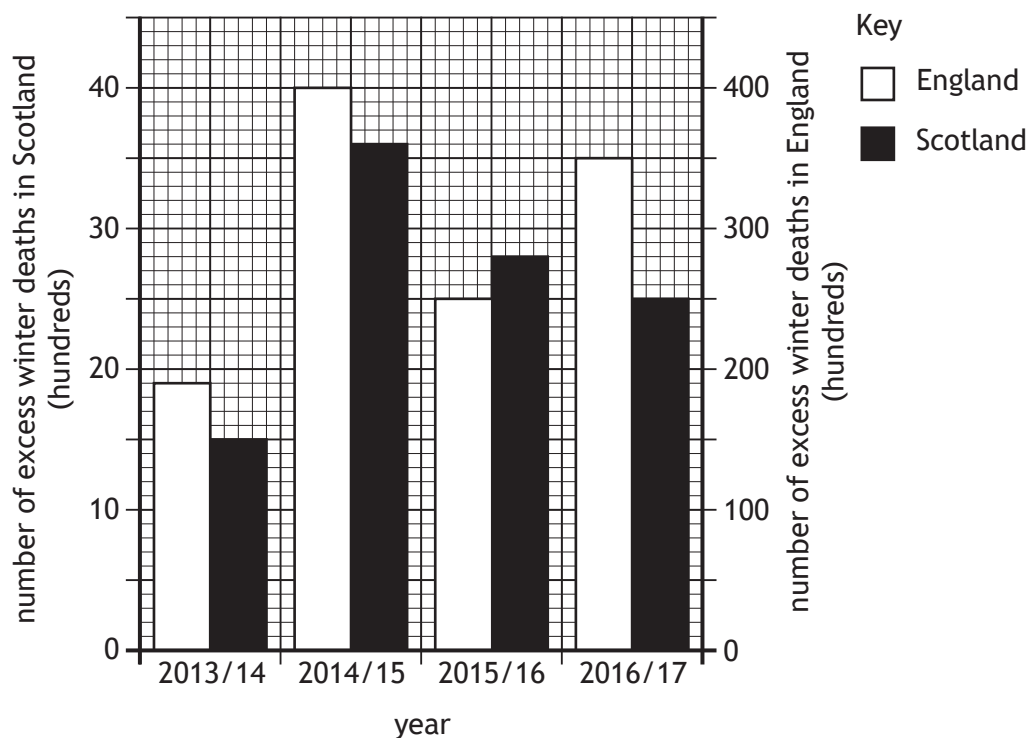

12. (b) (continued)

MARKS

DO NOT
WRITE IN
THIS
MARGIN

- (i) Describe one similarity and one difference in the trends in the number of excess winter deaths between the two countries.

2

Similarity _____

Difference _____

- (ii) Explain how the data should be expressed to allow a valid comparison of excess winter deaths in Scotland compared to England in each year.

1

- (iii) Express, as a simple whole number ratio, the number of excess winter deaths in Scotland compared to those in England in the winter of 2014/15.

1

Space for calculation

_____ : _____
Scotland England

- (c) The table shows the percentage of excess winter deaths caused by respiratory and circulatory diseases in England in the winter of 2015/16.

Diseases	Excess winter deaths (%)
circulatory	18
respiratory	39

Use information in the table and graph to calculate the number of excess winter deaths in England caused by respiratory diseases in 2015/16.

1

Space for calculation



* X 8 4 0 7 6 0 1 2 3 *

12. (continued)

- (d) The influenza virus can cause respiratory diseases.

Describe how the influenza virus can change from one winter to the next.

1

- (e) Name the type of cells that form a physical barrier in the inner lining of the respiratory system.

1



13. Whooping cough is an infectious disease caused by a bacterium.
The graph shows the number of whooping cough cases in Scotland between 2012 and 2016.

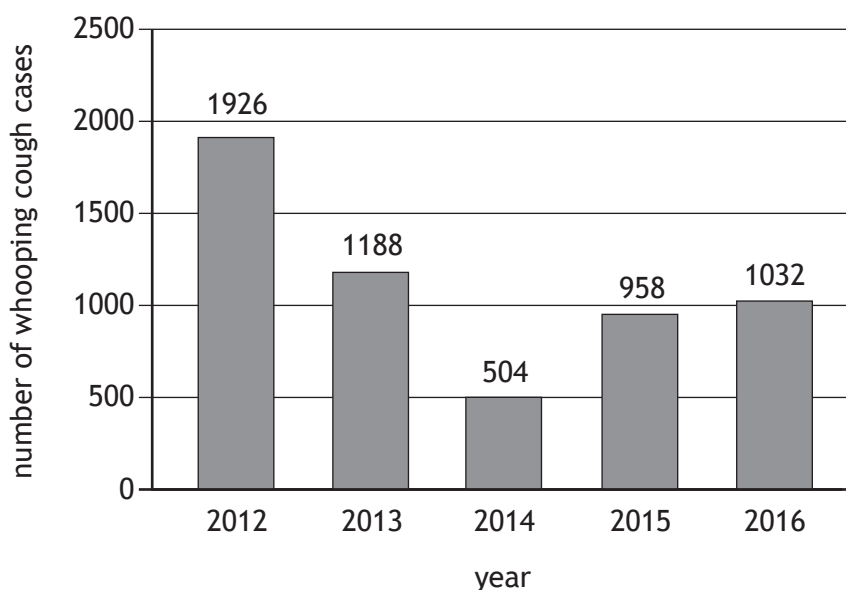

- (a) A vaccine for whooping cough was first introduced for pregnant women in Scotland in 2012.
- (i) Suggest a reason for the increase in the number of cases of whooping cough between 2014 and 2016. 1
- _____
- _____
- (ii) Calculate the percentage increase in cases from 2014 to 2016. 1
- Space for calculation*
- _____ %
- (b) Explain why vaccines do not cause disease in vaccinated individuals. 1
- _____
- _____
- (c) Name a substance that is added to a vaccine to make it more effective. 1
- _____



MARKS

DO NOT
WRITE IN
THIS
MARGIN

14. Attempt **either** A or B. Write your answer in the space below and on *page 27*.

A Discuss the use of antenatal screening and diagnostic testing to monitor the health of the developing fetus during pregnancy.

9

OR

B Discuss the structure and function of arteries, veins and capillaries in the circulatory system.

9

You may use labelled diagrams where appropriate.



* X 8 4 0 7 6 0 1 2 6 *