

FOR OFFICIAL USE

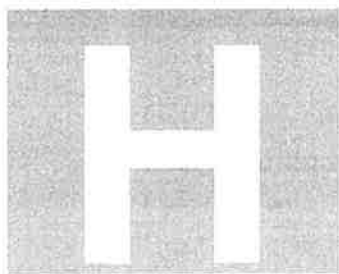

--	--	--	--	--	--

National
Qualifications
2026

Mark

--

X840/76/01

**Human Biology
Paper 2**

TUESDAY, 28 APRIL
10:10 AM – 12:30 PM



* X 8 4 0 7 6 0 1 *

Fill in these boxes and read what is printed below.

Full name of centre

--

Town

--

Forename(s)

--

Surname

--

Number of seat

--

Date of birth

Day

Month

Year

--	--

--	--

--	--

Scottish candidate number

--	--	--	--	--	--	--	--	--	--

Total marks — 95

Attempt ALL questions.

You may use a calculator.

Question 14 contains a choice.

Write your answers clearly in the spaces provided in this booklet. Additional space for answers and rough work is provided at the end of this booklet. If you use this space you must clearly identify the question number you are attempting. Any rough work must be written in this booklet. Score through your rough work when you have written your final copy.

Use blue or black ink.

Do not remove any exam materials. You must leave this booklet on your desk; if you do not, you could lose all the marks for this paper.



* X 8 4 0 7 6 0 1 0 1 *



Total marks — 95
 Attempt ALL questions
 Question 14 contains a choice

1. (a) The diagram shows the range of cells produced from blood stem cells found within the bone marrow.

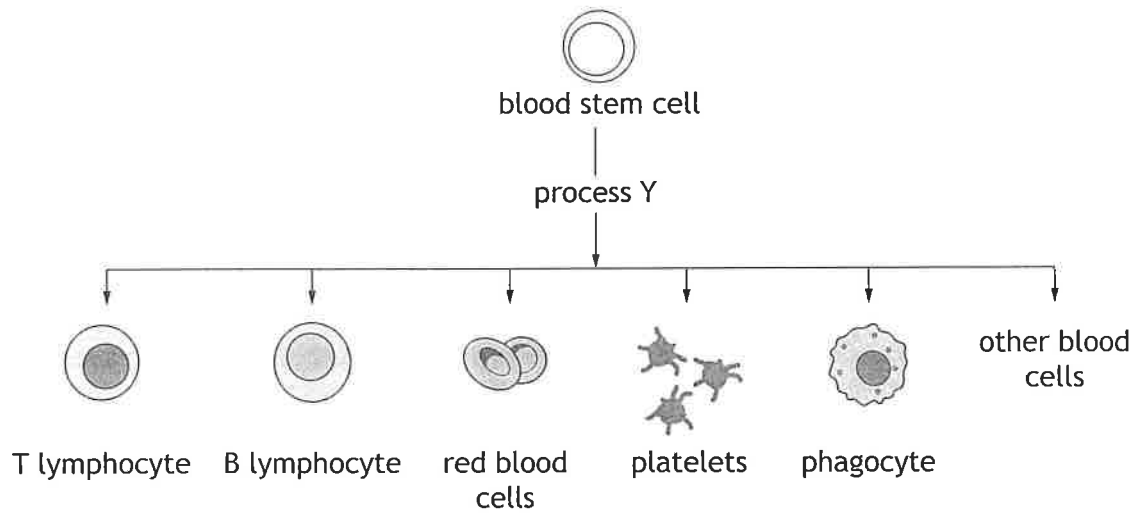

- (i) Name process Y. 1
- _____
- (ii) Using information from the diagram, explain why blood stem cells are described as multipotent. 1
- _____
- _____
- (iii) Describe the process that results in phagocytes producing different proteins to lymphocytes. 1
- _____
- _____
- (b) Leukaemia is a type of cancer that affects some blood cells.
- (i) Explain why these cancer cells divide excessively. 1
- _____
- _____



1. (b) (continued)

MARKS
DO NOT
WRITE IN
THIS
MARGIN

A patient with cancer was treated with chemotherapy that affected their white blood cell count.

The graph shows the patient's white blood cell count over time following this treatment.

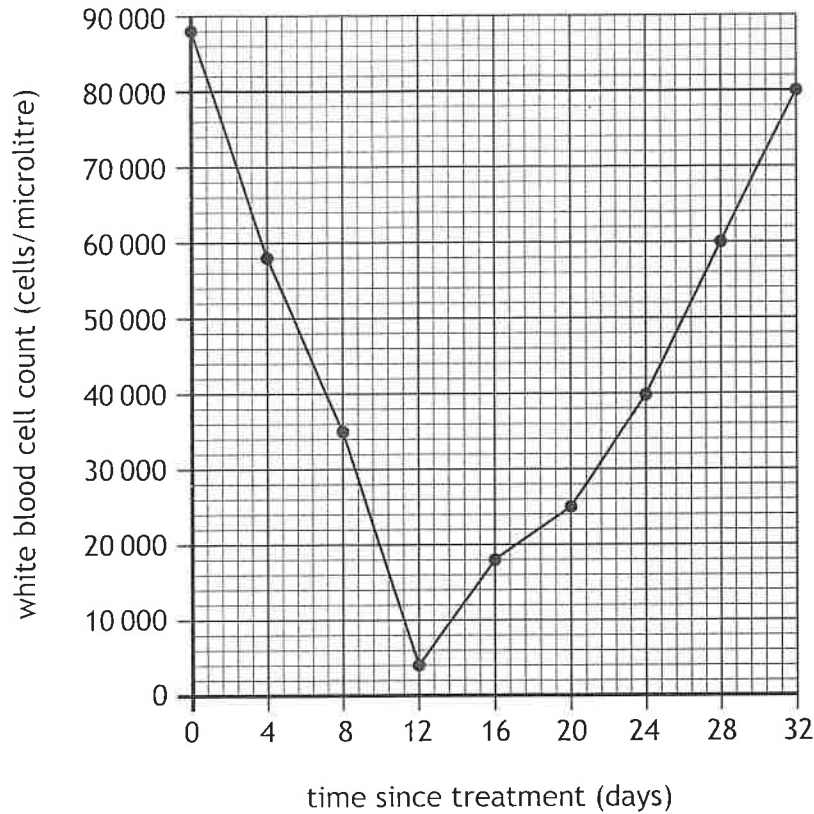

- (ii) Use data from the graph to describe the changes that occur in the white blood cell count from days 0 to 32.

2

- (iii) Use data from the graph to predict the white blood cell count on day 34.

1

_____ cells/microlitre

[Turn over



2. (a) The diagram shows the replication of DNA in a cell.

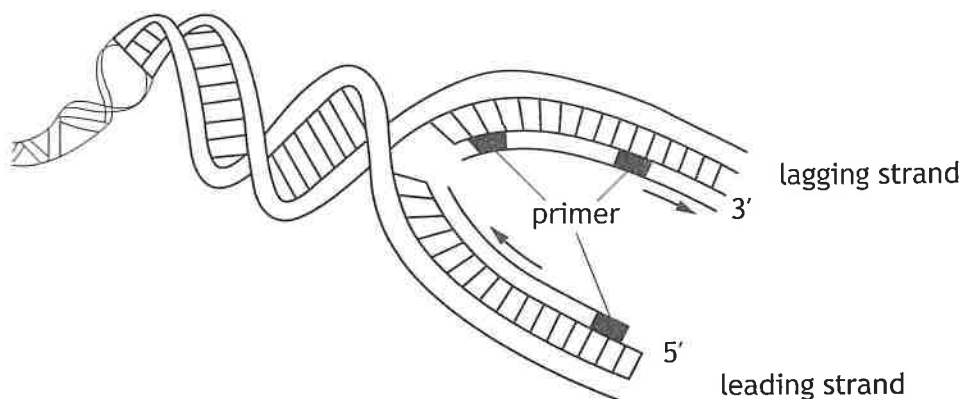

(i) Suggest what the arrows on the diagram indicate. 1

(ii) Explain why the lagging strand is replicated in fragments. 1

(iii) Name the enzyme that joins fragments together in the lagging strand. 1

(b) DNA is involved in gene expression to allow cells to synthesise proteins.
 The enzyme RNA polymerase is required in gene expression.
 Describe the role of this enzyme in the synthesis of a protein. 2



2. (continued)

(c) Transfer RNA (tRNA) is involved in gene expression.
Describe the structure of tRNA.

3

[Turn over



3. Haemoglobin is a protein that transports oxygen in the blood.

Individuals with sickle cell anaemia have two copies of a single gene mutation that results in the production of the protein haemoglobin S. Although haemoglobin S is the same length as haemoglobin it folds into a different shape.

DNA sequences from the same region of the gene for haemoglobin and haemoglobin S are shown.

haemoglobin T G A G G A C T C

haemoglobin S T G A G C A C T C

(a) State the sequence of bases in the mRNA transcript that would be formed from the haemoglobin S sequence shown.

1

(b) (i) Using information from the diagram, name the type of single gene mutation that causes sickle cell anaemia.

1

(ii) Explain why the changed sequence of bases in the gene for haemoglobin S codes for a different shaped protein.

1

(c) Suggest why individuals with sickle cell anaemia have increased blood lactate concentration and are more likely to experience muscle fatigue.

1

(d) In a country, 670 000 babies were born and tested for haemoglobin S.

Calculate the number of babies with haemoglobin S, if 1 in every 80 babies tests positive.

1

Space for calculation



4. The diagram shows part of the metabolic pathway of cellular respiration. The pathway includes the enzyme pyruvate dehydrogenase, which catalyses the conversion of pyruvate to an acetyl group.

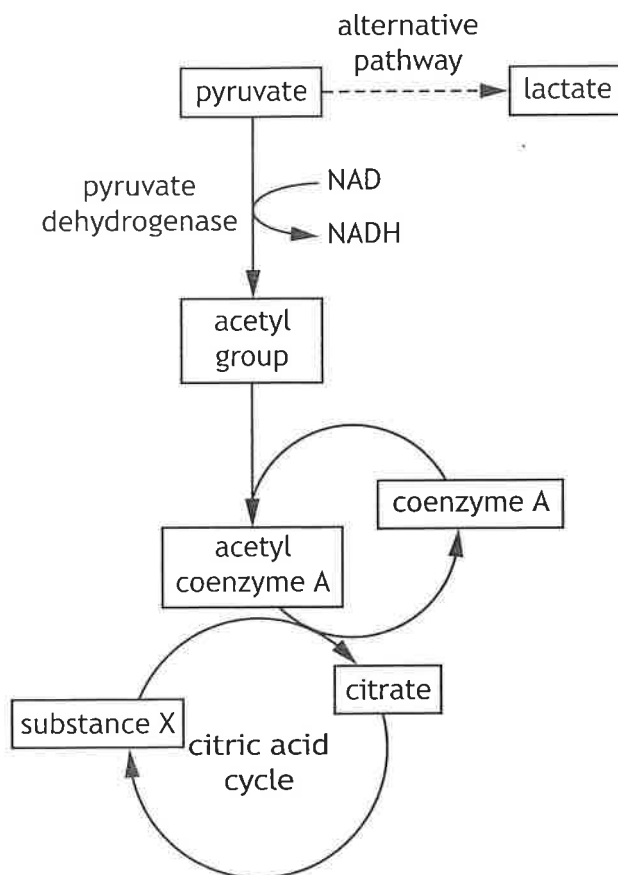

- (a) State the location of the production of pyruvate in a cell. 1
- _____
- (b) Describe the role of pyruvate dehydrogenase in the production of NADH. 1
- _____
- _____
- (c) Name substance X and describe its role in the synthesis of citrate. 2
- Substance X _____
- Role _____

[Turn over



4. (continued)

- (d) Pyruvate dehydrogenase deficiency (PDHD) is caused by a mutation, which results in individuals with non-functional pyruvate dehydrogenase. This mutation affects cellular respiration.

Describe the effect of PDHD on ATP and lactate production.

2

ATP production _____

Lactate production _____

- (e) One type of PDHD is caused by an autosomal recessive allele. A couple who are both unaffected by the condition have a child with PDHD.

- (i) Pharmacogenetics could be used in the treatment of this child.

Give an advantage of using pharmacogenetics.

1

- (ii) The couple are expecting a second child.

Calculate the percentage chance of this child having PDHD.

1

Space for calculation

_____ %



5. The graph shows the percentage of slow twitch and fast twitch muscle fibres in different types of athletes.

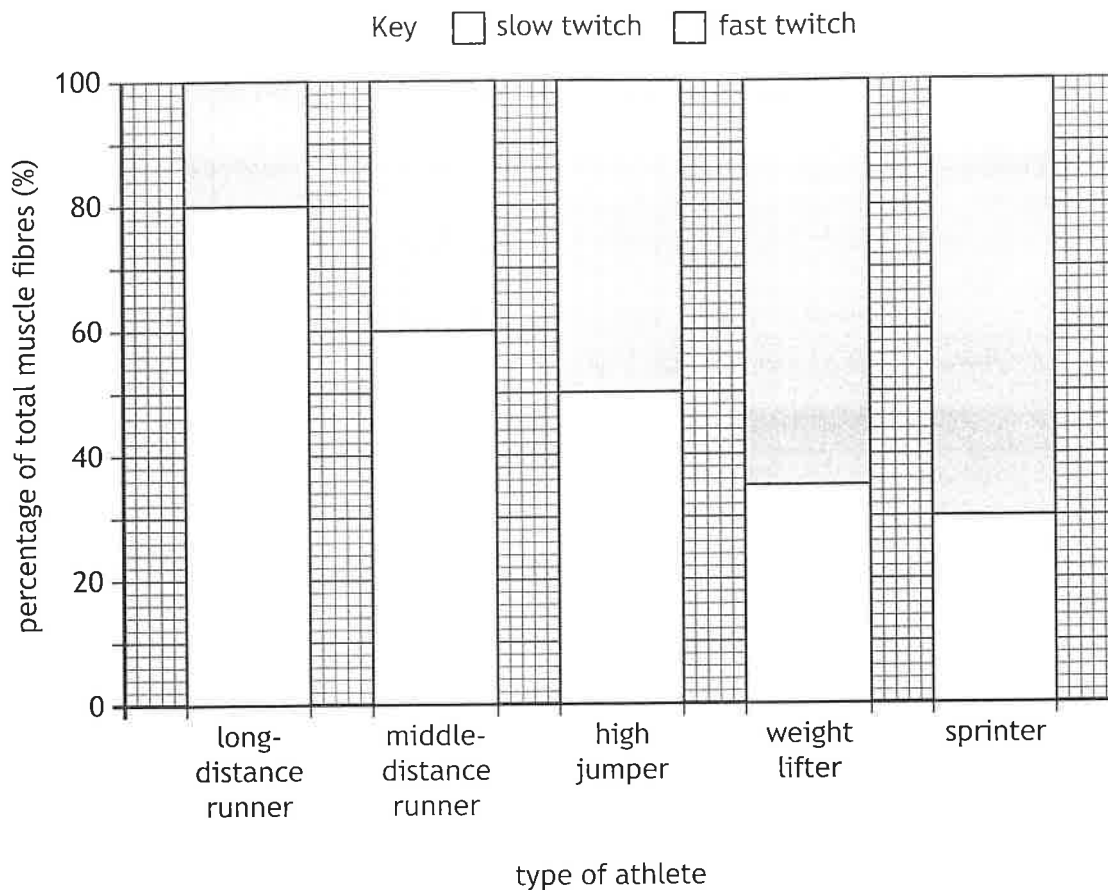

- (a) (i) Express, as a simple whole number ratio, the percentage of fast twitch muscle fibres in the long-distance runner, high jumper and weightlifter.
Space for calculation

1

_____ : _____ : _____
long-distance runner high jumper weightlifter



5. (a) (continued)

- (ii) Calculate how many times greater the percentage of fast twitch fibres in the muscles of the sprinter is compared to the muscles of the long-distance runner.

1

Space for calculation

_____ times greater

- (b) (i) State a feature of fast twitch muscle fibres that makes them useful for sprinting.

1

- (ii) Slow twitch muscle fibres have a higher concentration of myoglobin than fast twitch muscle fibres.

State the function of myoglobin and explain why slow twitch muscle fibres need to have a high concentration of myoglobin.

2

Function _____

Explanation _____

- (iii) Describe one other structural difference between slow twitch and fast twitch muscle fibres.

1

[Turn over



6. The menstrual cycle is hormonally controlled.

(a) Graph 1 shows the blood concentration of hormones produced by the pituitary gland in a female during one menstrual cycle.

Graph 1

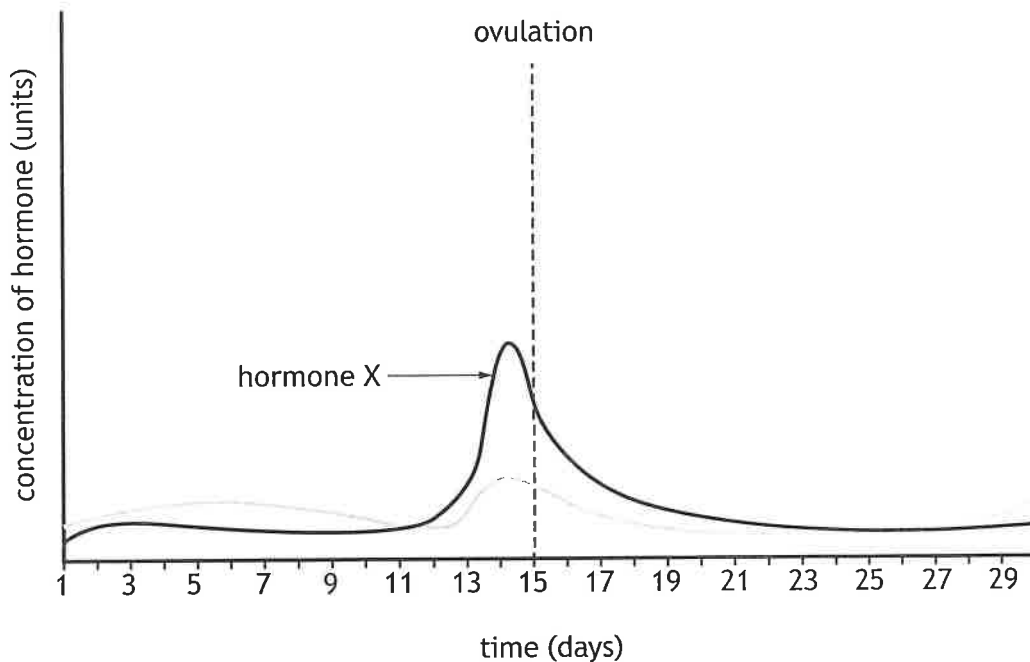

(i) Name hormone X.

1

(ii) Body temperature and cervical mucus consistency change throughout the menstrual cycle.

Describe the difference in a female's body temperature and cervical mucus consistency on day 16 compared to day 3.

2

Body temperature _____

Cervical mucus consistency _____



* X 8 4 0 7 6 0 1 1 2 *

6. (continued)

MARKS DO NOT WRITE IN THIS MARGIN

(b) Graph 2 shows the blood concentration of hormones produced by the ovaries in a female during one menstrual cycle.

Graph 2

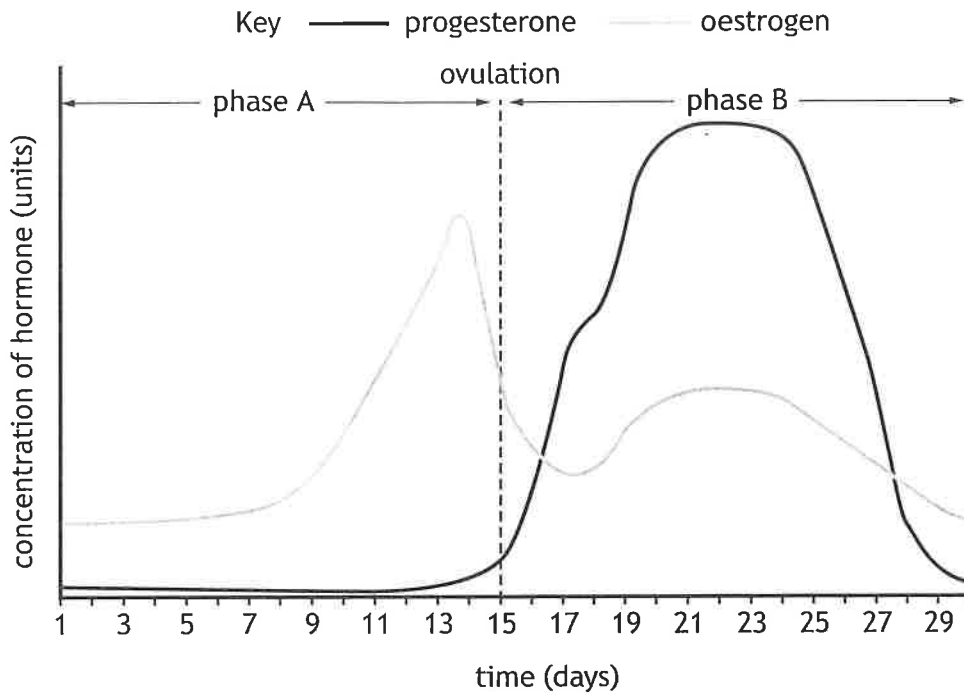

(i) Name phase A and phase B.

2

Phase A _____

Phase B _____

(ii) Describe the events that lead to an increase in progesterone levels during phase B.

2

(iii) In the next cycle, the female became pregnant.

Suggest one way in which the hormone concentration for this cycle would differ from Graph 2.

1

[Turn over



7. An investigation was set up to compare the elasticity of arteries and veins.
A section of vein was suspended from a clamp stand as shown in the diagram.

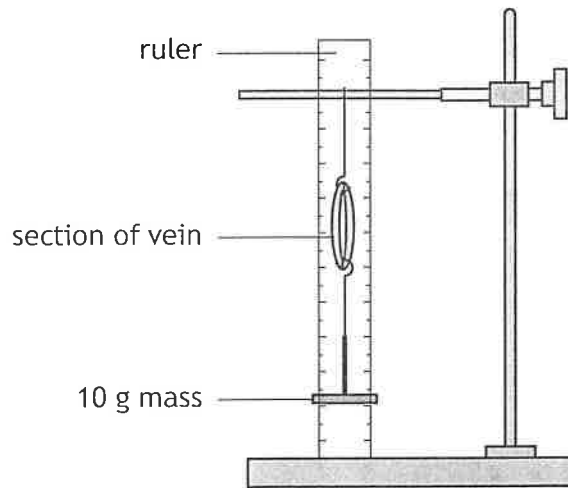

The length of the vein was measured.

A mass of 10 g was attached to the vein and the length of the vein was remeasured using the ruler.

This was repeated with masses of 20, 30 and 40 g. The investigation was then repeated with a section of artery.

The results are shown in Table 1.

Table 1

Mass (g)	Vein		Artery	
	Length (mm)	Change in length (%)	Length (mm)	Change in length (%)
0	25	0	20	0
10	27	8	22	10
20	29	16	24	20
30	31	24	27	
40	31	24	30	50

- (a) Calculate the percentage change in length for the artery with a 30 g mass attached.

Space for calculation

1

_____ %



7. (continued)

MARKS
DO NOT
WRITE IN
THIS
MARGIN

- (b) (i) Explain why it was necessary to calculate the percentage change in the length of each blood vessel.

1

- (ii) Describe how the reliability of these results could be improved.

1

- (c) At the end of the investigation the masses were removed, and the lengths of the artery and vein were remeasured.

The values were recorded in **Table 2**.

Table 2

Blood vessel	Length (mm)	
	Start of investigation	End of investigation
Vein	25	30
Artery	20	20

- (i) Suggest a difference between the structure of veins and arteries that leads to the difference in results shown in **Table 2**.

1

- (ii) Explain why it is important that the walls of arteries can stretch and recoil.

1

- (d) Describe a feature of artery walls that allows them to control blood flow.

1

[Turn over



8. Studies have shown that the percentage of infertile males in the UK is increasing. One of the main causes of male infertility is a low sperm count.

Mice were used as a model organism in an investigation into the effect of regular alcohol consumption on sperm count over a 120-day period.

140 mice were divided into two groups.

Group 1 received water.

Group 2 received water and a daily dose of alcohol.

Semen samples were collected from the mice throughout the investigation and sperm counts recorded.

The results of the investigation are shown in the table.

Day semen sample taken	Average sperm count (million/cm ³)	
	Group 1	Group 2
0	45.2	45.0
30	44.7	42.2
60	45.3	40.2
90	44.5	38.2
120	45.0	36.2

- (a) (i) State the purpose of including group 1 in this investigation. 1

- (ii) Identify two variables, not already mentioned, that would need to be controlled to make the investigation valid. 2

1. _____

2. _____



8. (continued)

MARKS DO NOT WRITE IN THIS MARGIN

- (b) (i) On the grid, complete the line graph to show the results of the investigation for **group 2**. The results of group 1 are shown.
 (Additional graph paper, if required, can be found on *page 28*.)

2

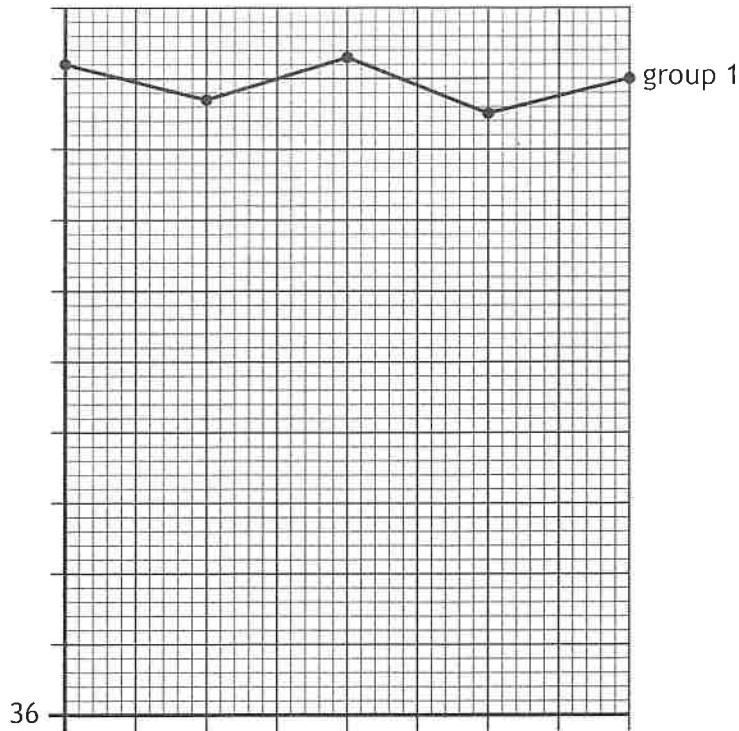

- (ii) State the conclusion that can be made from these results.

1

- (iii) If the study continued for another 15 days, predict the average sperm count of the mice in group 2.

1

_____ million/cm³

- (c) Artificial insemination can be used if a male has a low sperm count.

Describe a feature of artificial insemination that increases the chances of fertilisation.

1

[Turn over



9. Cholesterol is essential for myelin sheath regeneration and maintenance.

(a) (i) State another function of cholesterol in the body.

1

(ii) Describe the importance of the myelin sheath.

1

(b) The diagram shows the transport of cholesterol through an artery by molecules A and B.

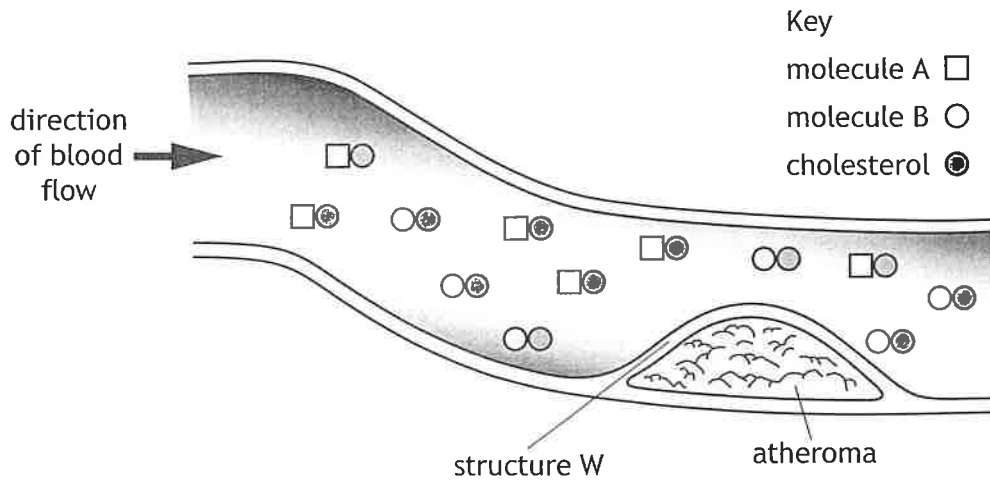

Molecule A transports cholesterol to body cells.

Molecule B prevents accumulation of cholesterol in the blood.

(i) Identify molecule B and describe how it prevents accumulation of cholesterol in the body.

2

Molecule B _____

Description _____



9. (b) (continued)

(ii) Describe how cholesterol uptake is limited in body cells with sufficient cholesterol.

1

(iii) Molecule A can also deposit cholesterol as part of the fatty material in an atheroma under structure W.

Name structure W and another substance that can be found in an atheroma.

2

Structure W _____

Other substance _____

(c) If an atheroma ruptures, clotting factors lead to the conversion of the enzyme prothrombin to its active form thrombin.

Hirudin is a molecule that acts as a competitive inhibitor of thrombin.

(i) Suggest how the inhibitor hirudin prevents the formation of a clot.

2

(ii) Suggest how the effect of hirudin on the clotting process could be reversed.

1

[Turn over



* X 8 4 0 7 6 0 1 1 9 *

10. Changes in an individual's heart rate and duration of stages in the cardiac cycle at rest and during exercise are shown in the table.

Activity	Heart rate (bpm)	Duration (s)		
		Atrial systole	Ventricular systole	Diastole
Rest	60	0.18	0.22	0.60
Exercise	120	0.10	0.14	

(a) Calculate the duration of diastole during exercise.

1

Space for calculation

_____ s

(b) Atrial systole is brought about by structure X.

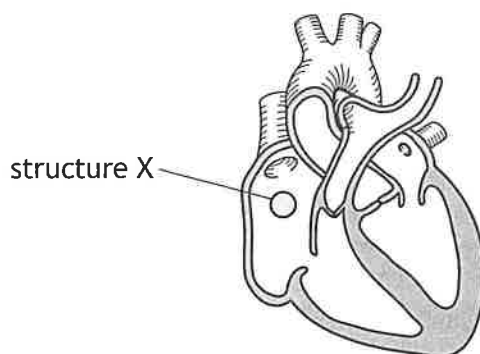

(i) Name structure X.

1

(ii) A stethoscope is used to listen to heart sounds during the cardiac cycle.

Describe the events during the cardiac cycle in the heart that are responsible for these sounds.

2



11. Flashcards are often used in the rehearsal of information during revision.

A student created flashcards to revise for their N5 Biology exam. The flashcards had a biological term on the front and an explanation on the back. One of the flashcards is shown in the diagram.

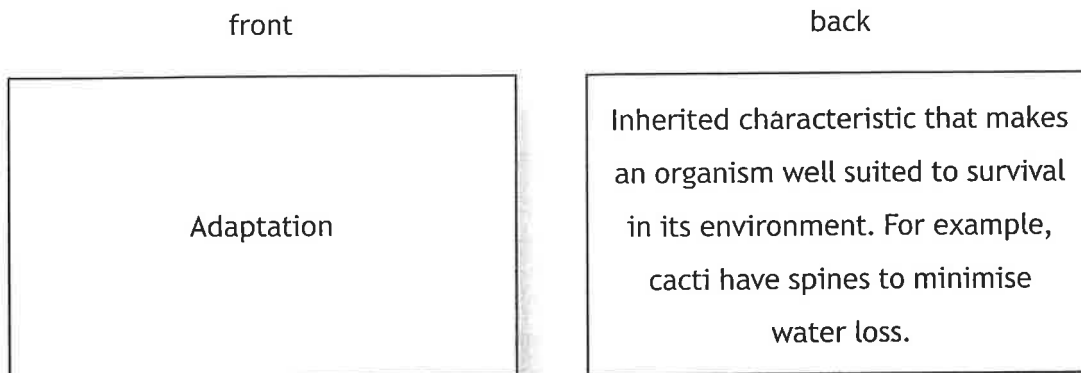

(a) (i) The back of this flashcard shows another method that improves the transfer of information to the long-term memory.

Name this method.

1

(ii) Explain why this method leads to improved information retention compared to rehearsal of the information.

1

(b) State what would happen to the information if it was not transferred from the short-term memory to long-term memory.

1

(c) The short-term memory has a limited capacity.

Name the method that increases the capacity of short-term memory and suggest how this method can increase the capacity.

2

Name _____

Suggestion _____

[Turn over



* X 8 4 0 7 6 0 1 2 1 *

12. A species of bacterium can be found in the upper respiratory tract of individuals where it is usually harmless and causes no symptoms.

If an individual contracts influenza, the normally harmless bacterium can move to the lower respiratory tract and cause pneumonia.

The graph shows the number of emergency hospital admissions and death rate for pneumonia in a country from 2013 to 2019.

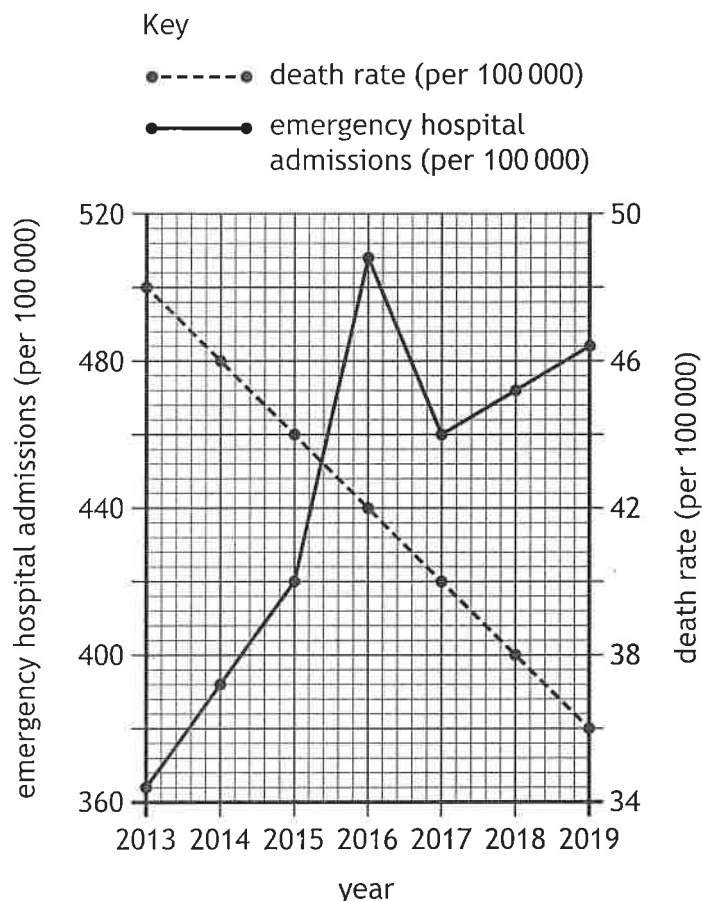

(a) (i) Calculate the annual average increase in emergency hospital admissions for pneumonia over the six-year period from 2013 to 2019.

1

Space for calculation

_____ per 100 000/year

(ii) State the death rate from pneumonia when the number of emergency hospital admissions was 420 per 100 000.

1

_____ per 100 000



* X 8 4 0 7 6 0 1 2 2 *

12 (a) (continued)

- (iii) Calculate the difference between emergency hospital admissions and death rates for pneumonia in 2016.

1

Space for calculation

_____ per 100 000

- (iv) Using the information provided, suggest a reason for the sharp increase in the number of emergency hospital admissions for pneumonia from 2015 to 2016.

1

- (v) In 2017 the population of the country was 50 million and the total number of deaths in the country was 500 000.

Using data from the graph, calculate the percentage of the total number of deaths that were due to pneumonia.

1

Space for calculation

_____ %

- (b) Individuals in this country are offered the influenza vaccine.

- (i) Name a source of antigens that can be used to produce a vaccine.

1

- (ii) Explain why an adjuvant is added to a vaccine.

1

[Turn over



* X 8 4 0 7 6 0 1 2 3 *

13. The diagram represents synapses from the brains of two individuals. Individual X has Parkinson's disease and individual Y does not have Parkinson's disease.

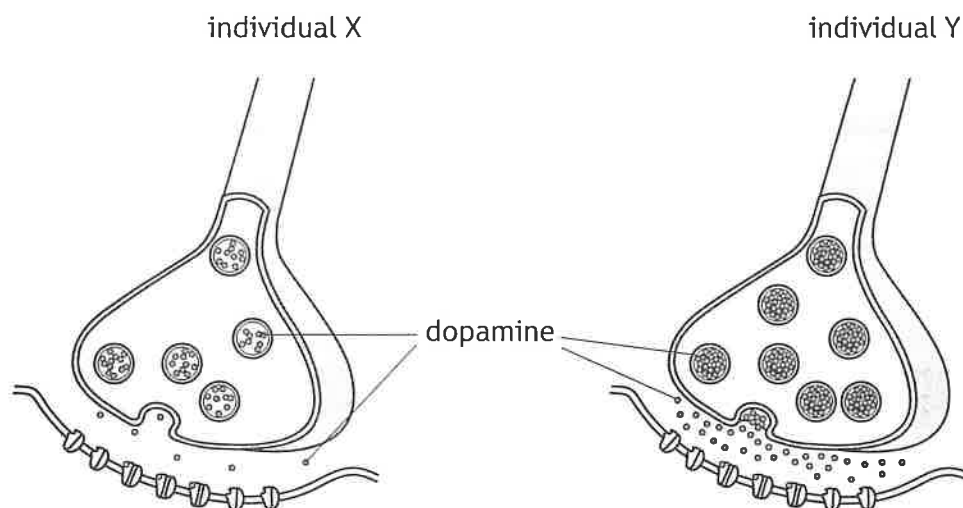

- (a) (i) Using information in the diagram, describe an effect of Parkinson's disease on the synapses of individual X. 1

- (ii) State an effect of the neurotransmitter dopamine. 1



* X 8 4 0 7 6 0 1 2 4 *

13. (continued)

- (b) Parkinson's disease can be treated with a drug that mimics the action of dopamine at a synapse.

Name the type of drug that would mimic the action of dopamine.

1

- (c) Describe how the release of neurotransmitters at a synapse triggers an impulse in the postsynaptic neuron.

2

[Turn over



14. Attempt either A or B.

Write your answer in the space below and on *page 27*.

A Write notes on the role of B and T lymphocytes in the specific immune response to a pathogen.

8

OR

B Write notes on the divisions of the nervous system to include the central nervous system and the peripheral nervous system.

8

You may use labelled diagrams where appropriate.

