

X056/301

NATIONAL
QUALIFICATIONS
2000

THURSDAY, 25 MAY
9.00 AM – 10.10 AM

MATHEMATICS
HIGHER
Paper 1
(Non-calculator)

Read Carefully

- 1 Calculators may **NOT** be used in this paper.
- 2 There are three Sections in this paper.
 - Section A assesses the compulsory units Mathematics 1 and 2.
 - Section B assesses the optional unit Mathematics 3.
 - Section C assesses the optional unit Statistics.Candidates must attempt **all** questions in Section A (Mathematics 1 and 2) **and either** Section B (Mathematics 3)
or Section C (Statistics).
- 3 Full credit will be given only where the solution contains appropriate working.
- 4 Answers obtained by readings from scale drawings will not receive any credit.

FORMULAE LIST

Circle:

The equation $x^2 + y^2 + 2gx + 2fy + c = 0$ represents a circle centre $(-g, -f)$ and radius $\sqrt{g^2 + f^2 - c}$.

The equation $(x - a)^2 + (y - b)^2 = r^2$ represents a circle centre (a, b) and radius r .

Scalar Product: $\mathbf{a} \cdot \mathbf{b} = |\mathbf{a}| |\mathbf{b}| \cos \theta$, where θ is the angle between \mathbf{a} and \mathbf{b}

or $\mathbf{a} \cdot \mathbf{b} = a_1 b_1 + a_2 b_2 + a_3 b_3$ where $\mathbf{a} = \begin{pmatrix} a_1 \\ a_2 \\ a_3 \end{pmatrix}$ and $\mathbf{b} = \begin{pmatrix} b_1 \\ b_2 \\ b_3 \end{pmatrix}$.

Trigonometric formulae: $\sin(A \pm B) = \sin A \cos B \pm \cos A \sin B$

$$\cos(A \pm B) = \cos A \cos B \mp \sin A \sin B$$

$$\sin 2A = 2 \sin A \cos A$$

$$\cos 2A = \cos^2 A - \sin^2 A = 2 \cos^2 A - 1 = 1 - 2 \sin^2 A$$

Table of standard derivatives and integrals:

$f(x)$	$f'(x)$
$\sin ax$	$a \cos ax$
$\cos ax$	$-a \sin ax$

$f(x)$	$\int f(x) dx$
$\sin ax$	$-\frac{1}{a} \cos ax + C$
$\cos ax$	$\frac{1}{a} \sin ax + C$

ALL candidates should attempt this Section.

- A1.** On the coordinate diagram shown, A is the point (6, 8) and B is the point (12, -5). Angle AOC = p and angle COB = q .
Find the exact value of $\sin(p + q)$.

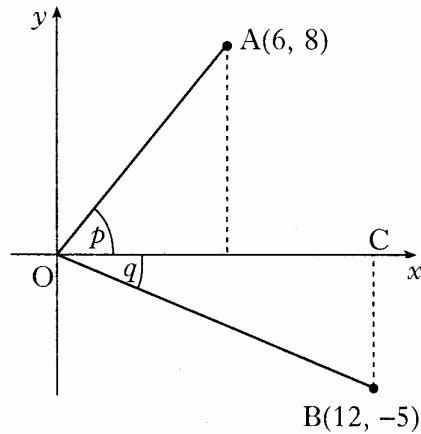

4

- A2.** A sketch of the graph of $y = f(x)$ where $f(x) = x^3 - 6x^2 + 9x$ is shown below. The graph has a maximum at A and a minimum at B(3, 0).

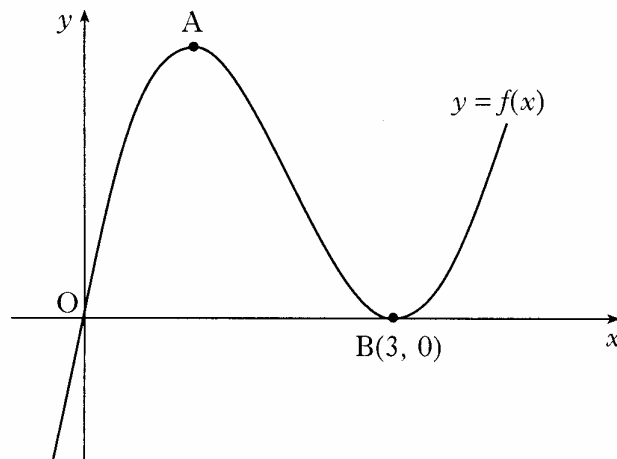

- (a) Find the coordinates of the turning point at A. 4
- (b) Hence sketch the graph of $y = g(x)$ where $g(x) = f(x + 2) + 4$.
Indicate the coordinates of the turning points. There is no need to calculate the coordinates of the points of intersection with the axes. 2
- (c) Write down the range of values of k for which $g(x) = k$ has 3 real roots. 1

[Turn over

- A3.** Find the size of the angle a° that the line joining the points $A(0, -1)$ and $B(3\sqrt{3}, 2)$ makes with the positive direction of the x -axis.

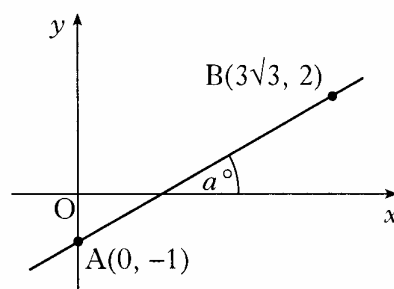

3

- A4.** The diagram shows a sketch of the graphs of $y = 5x^2 - 15x - 8$ and $y = x^3 - 12x + 1$. The two curves intersect at A and touch at B, ie at B the curves have a common tangent.

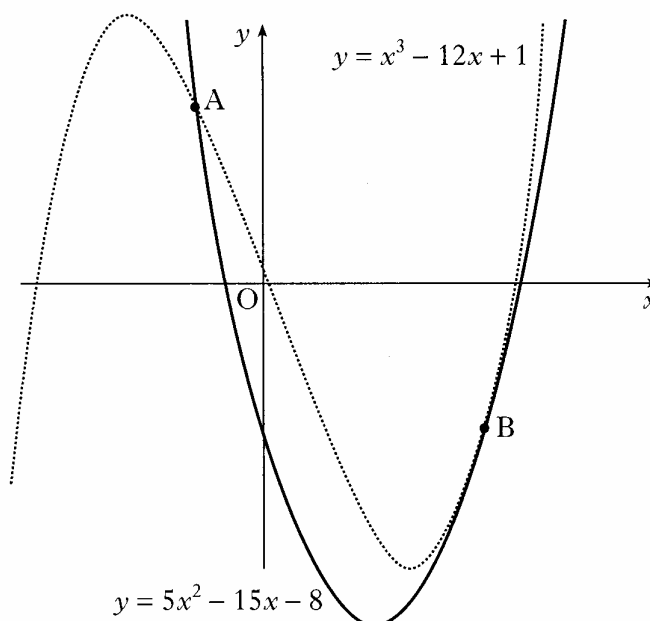

- (a) (i) Find the x -coordinates of the points on the curves where the gradients are equal. 4
- (ii) By considering the corresponding y -coordinates, or otherwise, distinguish geometrically between the two cases found in part (i). 1
- (b) The point A is $(-1, 12)$ and B is $(3, -8)$.
Find the area enclosed between the two curves. 5

- A5.** Two sequences are generated by the recurrence relations $u_{n+1} = au_n + 10$ and $v_{n+1} = a^2v_n + 16$.

The two sequences approach the same limit as $n \rightarrow \infty$.

Determine the value of a and evaluate the limit.

5

- A6.** For what range of values of k does the equation $x^2 + y^2 + 4kx - 2ky - k - 2 = 0$ represent a circle?

5

[END OF SECTION A]

Candidates should now attempt

EITHER Section B (Mathematics 3) on *Page six*

OR Section C (Statistics) on *Pages seven and eight*

[Turn over

ONLY candidates doing the course Mathematics 1, 2 and 3 should attempt this Section.

- B7.** VABCD is a pyramid with a rectangular base ABCD.

Relative to some appropriate axes,

$$\vec{VA} \text{ represents } -7\mathbf{i} - 13\mathbf{j} - 11\mathbf{k}$$

$$\vec{AB} \text{ represents } 6\mathbf{i} + 6\mathbf{j} - 6\mathbf{k}$$

$$\vec{AD} \text{ represents } 8\mathbf{i} - 4\mathbf{j} + 4\mathbf{k}.$$

K divides BC in the ratio 1:3.

Find VK in component form.

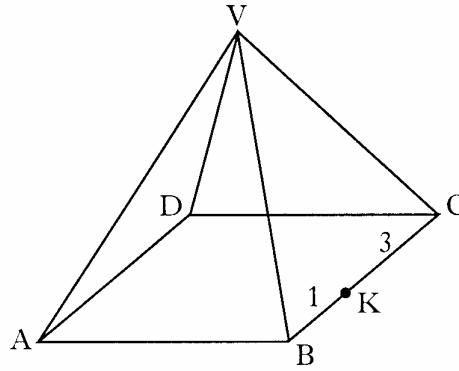

3

- B8.** The graph of $y = f(x)$ passes through the point $\left(\frac{\pi}{9}, 1\right)$.

If $f'(x) = \sin(3x)$, express y in terms of x .

4

- B9.** Evaluate $\log_5 2 + \log_5 50 - \log_5 4$.

3

- B10.** Find the maximum value of $\cos x - \sin x$ and the value of x for which it occurs in the interval $0 \leq x \leq 2\pi$.

6

[END OF SECTION B]

X056/302

NATIONAL
QUALIFICATIONS
2000

THURSDAY, 25 MAY
10.30 AM – 12.00 NOON

**MATHEMATICS
HIGHER**
Paper 2

Read Carefully

1 **Calculators may be used in this paper.**

2 There are three Sections in this paper.

Section A assesses the compulsory units Mathematics 1 and 2.

Section B assesses the optional unit Mathematics 3.

Section C assesses the optional unit Statistics.

Candidates must attempt **all** questions in Section A (Mathematics 1 and 2) **and either** Section B (Mathematics 3)

or Section C (Statistics).

3 Full credit will be given only where the solution contains appropriate working.

4 Answers obtained by readings from scale drawings will not receive any credit.

ALL candidates should attempt this Section.

A1. The diagram shows a sketch of the graph of $y = x^3 - 3x^2 + 2x$.

- (a) Find the equation of the tangent to this curve at the point where $x = 1$.
- (b) The tangent at the point $(2, 0)$ has equation $y = 2x - 4$. Find the coordinates of the point where this tangent meets the curve again.

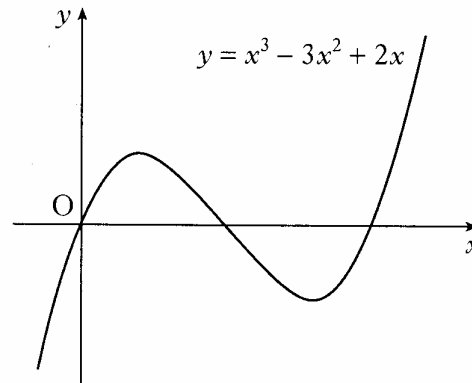

5

5

A2. (a) Find the equation of AB, the perpendicular bisector of the line joining the points $P(-3, 1)$ and $Q(1, 9)$.

- (b) C is the centre of a circle passing through P and Q. Given that QC is parallel to the y-axis, determine the equation of the circle.

- (c) The tangents at P and Q intersect at T.

Write down

- (i) the equation of the tangent at Q
- (ii) the coordinates of T.

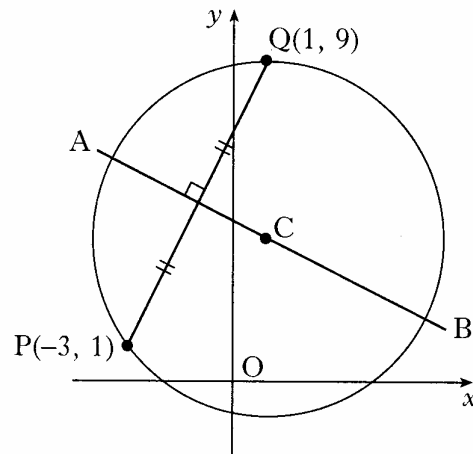

4

3

2

A3. $f(x) = 3 - x$ and $g(x) = \frac{3}{x}$, $x \neq 0$.

- (a) Find $p(x)$ where $p(x) = f(g(x))$.

2

- (b) If $q(x) = \frac{3}{3-x}$, $x \neq 3$, find $p(q(x))$ in its simplest form.

3

- A4.** The parabola shown crosses the x -axis at $(0, 0)$ and $(4, 0)$, and has a maximum at $(2, 4)$.

The shaded area is bounded by the parabola, the x -axis and the lines $x = 2$ and $x = k$.

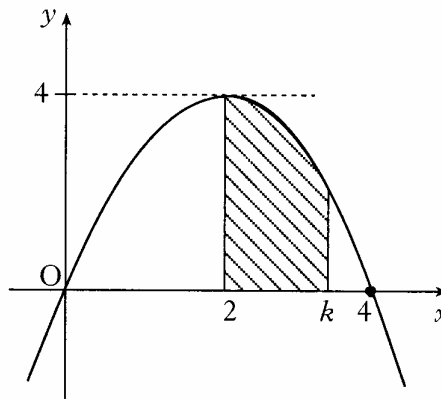

- (a) Find the equation of the parabola.
 (b) Hence show that the shaded area, A , is given by

$$A = -\frac{1}{3}k^3 + 2k^2 - \frac{16}{3}.$$

2

3

- A5.** Solve the equation $3 \cos 2x^\circ + \cos x^\circ = -1$ in the interval $0 \leq x \leq 360$.

5

- A6.** A goldsmith has built up a solid which consists of a triangular prism of fixed volume with a regular tetrahedron at each end.

The surface area, A , of the solid is given by

$$A(x) = \frac{3\sqrt{3}}{2} \left(x^2 + \frac{16}{x} \right)$$

where x is the length of each edge of the tetrahedron.

Find the value of x which the goldsmith should use to minimise the amount of gold plating required to cover the solid.



6

[END OF SECTION A]

Candidates should now attempt

EITHER Section B (Mathematics 3) on *Pages five and six*

OR Section C (Statistics) on *Pages seven and eight*

ONLY candidates doing the course Mathematics 1, 2 and 3 should attempt this Section.

B7. For what value of t are the vectors $u = \begin{pmatrix} t \\ -2 \\ 3 \end{pmatrix}$ and $v = \begin{pmatrix} 2 \\ 10 \\ t \end{pmatrix}$ perpendicular? 2

B8. Given that $f(x) = (5x - 4)^{\frac{1}{2}}$, evaluate $f'(4)$. 3

- B9. A cuboid measuring 11 cm by 5 cm by 7 cm is placed centrally on top of another cuboid measuring 17 cm by 9 cm by 8 cm.
Coordinate axes are taken as shown.

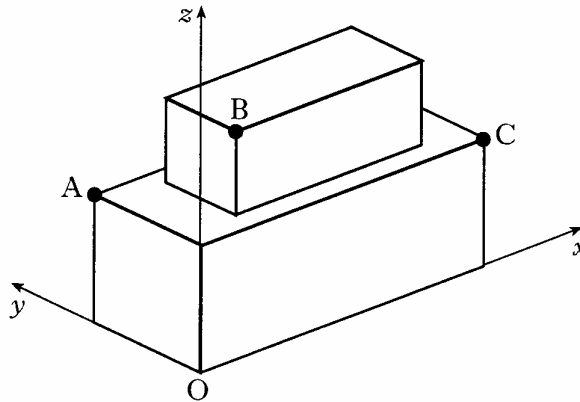
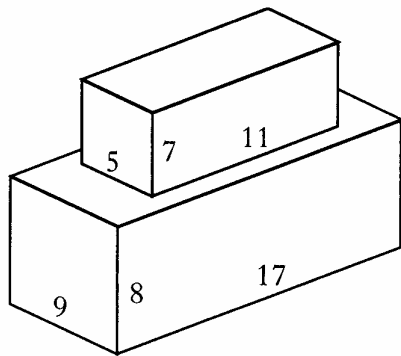

- (a) The point A has coordinates $(0, 9, 8)$ and C has coordinates $(17, 0, 8)$.

Write down the coordinates of B.

1

- (b) Calculate the size of angle ABC.

6

[Turn over

B10. Find $\int \frac{1}{(7-3x)^2} dx$.

Marks
2

B11. The results of an experiment give rise to the graph shown.

- (a) Write down the equation of the line in terms of P and Q .

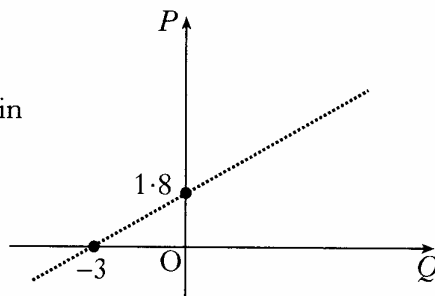

2

It is given that $P = \log_e p$ and $Q = \log_e q$.

- (b) Show that p and q satisfy a relationship of the form $p = aq^b$, stating the values of a and b .

4

[END OF SECTION B]